

## Kinematics of Machines

### CHAPTER - I

**Mechanics:** It is that branch of scientific analysis which deals with motion, time and force.

**Kinematics** is the study of motion, without considering the forces which produce that motion. Kinematics of machines deals with the study of the relative motion of machine parts. It involves the study of position, displacement, velocity and acceleration of machine parts.

**Dynamics** of machines involves the study of forces acting on the machine parts and the motions resulting from these forces.

**Plane motion:** A body has plane motion, if all its points move in planes which are parallel to some reference plane. A body with plane motion will have only three degrees of freedom. I.e., linear along two axes parallel to the reference plane and rotational/angular about the axis perpendicular to the reference plane. (eg. linear along X and Z and rotational about Y.) The reference plane is called plane of motion. Plane motion can be of three types. 1) Translation 2) rotation and 3) combination of translation and rotation.

**Translation:** A body has translation if it moves so that all straight lines in the body move to parallel positions. Rectilinear translation is a motion wherein all points of the body move in straight lie paths. Eg. The slider in slider crank mechanism has rectilinear translation. (link 4 in fig.1.1)

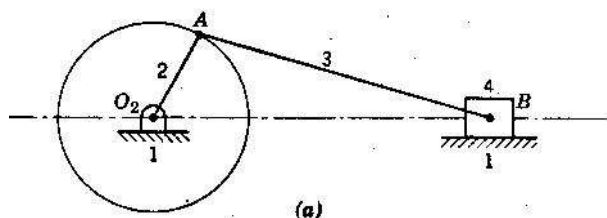

Fig.1.1

Translation, in which points in a body move along curved paths, is called curvilinear translation. The tie rod connecting the wheels of a steam locomotive has curvilinear translation. (link 3 in fig.1.2)

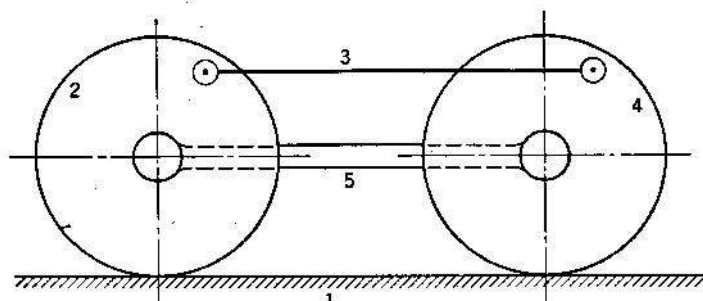

Fig.1.2

**Rotation:** In rotation, all points in a body remain at fixed distances from a line which is perpendicular to the plane of rotation. This line is the axis of rotation and points in the body describe circular paths about it. (Eg. link 2 in Fig.1.1 and links 2 & 4 in Fig.1.2)

**Translation and rotation:** It is the combination of both translation and rotation which is exhibited by many machine parts. (Eg. link 3 in Fig.1.1)

**Link or element:** It is the name given to any body which has motion relative to another. All materials have some elasticity. A rigid link is one, whose deformations are so small that they can be neglected in determining the motion parameters of the link.

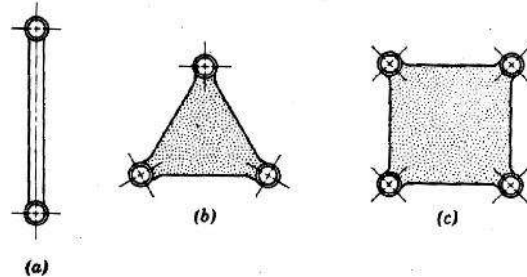

Fig.1.3

**Binary link:** Link which is connected to other links at two points. (Fig.1.3 a)

**Ternary link:** Link which is connected to other links at three points. (Fig.1.3 b)

**Quaternary link:** Link which is connected to other links at four points. (Fig.1.3 c)

**Pairing elements:** the geometrical forms by which two members of a mechanism are joined together, so that the relative motion between these two is consistent are known as pairing elements and the pair so formed is called kinematic pair. Each individual link of a mechanism forms a pairing element.

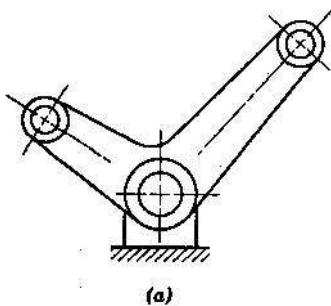

Fig.1.4 Kinematic pair

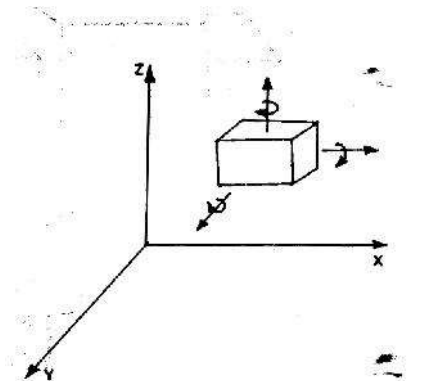

Fig.1.5

**Degrees of freedom (DOF):** It is the number of independent coordinates required to describe the position of a body in space. A free body in space (fig 1.5) can have six degrees of freedom. I.e., linear positions along x, y and z axes and rotational/angular positions with respect to x, y and z axes.

In a kinematic pair, depending on the constraints imposed on the motion, the links may lose some of the six degrees of freedom.

**Types of kinematic pairs:**

**(i) Based on nature of contact between elements:**

- (a) **Lower pair.** If the joint by which two members are connected has surface contact, the pair is known as lower pair. Eg. pin joints, shaft rotating in bush, slider in slider crank mechanism.

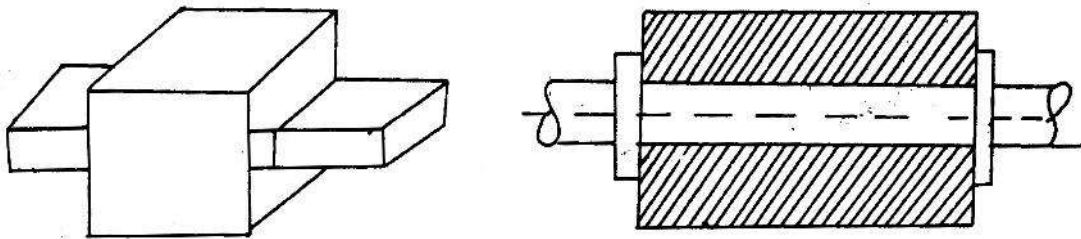

Fig.1.6 Lower pairs

- (b) **Higher pair.** If the contact between the pairing elements takes place at a point or along a line, such as in a ball bearing or between two gear teeth in contact, it is known as a higher pair.

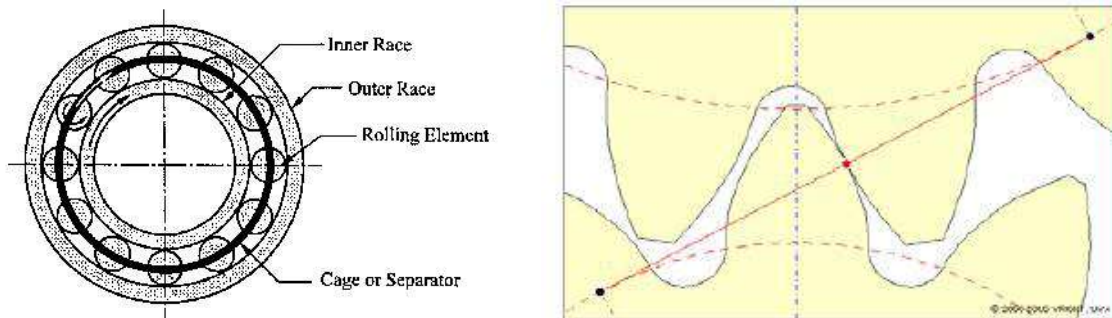

Fig.1.7 Higher pairs

**(ii) Based on relative motion between pairing elements:**

- (a) **Sliding pair.** Sliding pair is constituted by two elements so connected that one is constrained to have a sliding motion relative to the other.  $DOF = 1$

(b) **Turning pair (revolute pair).** When connections of the two elements are such that only a constrained motion of rotation of one element with respect to the other is possible, the pair constitutes a turning pair.  $DOF = 1$

(c) **Cylindrical pair.** If the relative motion between the pairing elements is the combination of turning and sliding, then it is called as cylindrical pair.  $DOF = 2$

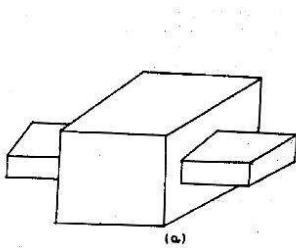

Fig.1.8 Sliding pair

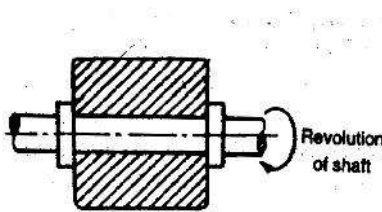

Fig.1.9 Turning pair

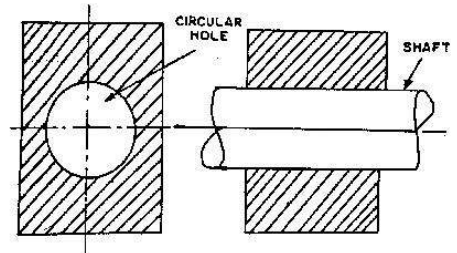

Fig.1.10 Cylindrical pair

(d) **Rolling pair.** When the pairing elements have rolling contact, the pair formed is called rolling pair. Eg. Bearings, Belt and pulley.  $DOF = 1$

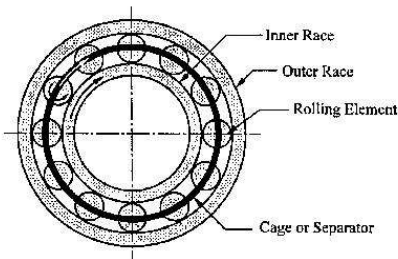

Fig.1.11 (a) Ball bearing

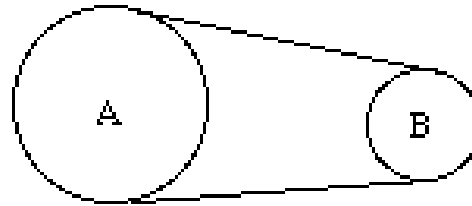

Fig.1.11(b) Belt and pulley

(e) **Spherical pair.** A spherical pair will have surface contact and three degrees of freedom. Eg. Ball and socket joint.  $DOF = 3$

(f) **Helical pair or screw pair.** When the nature of contact between the elements of a pair is such that one element can turn about the other by screw threads, it is known as screw pair. Eg. Nut and bolt.  $DOF = 1$

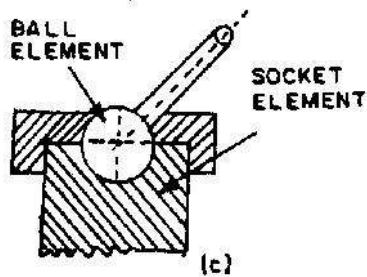

Fig.1.12 Ball and socket joint

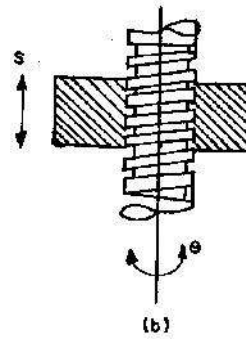

Fig.1.13 Screw pair

**(iii) Based on the nature of mechanical constraint.**

- (a) **Closed pair.** Elements of pairs held together mechanically due to their geometry constitute a closed pair. They are also called form-closed or self-closed pair.
- (b) **Unclosed or force closed pair.** Elements of pairs held together by the action of external forces constitute unclosed or force closed pair .Eg. Cam and follower.

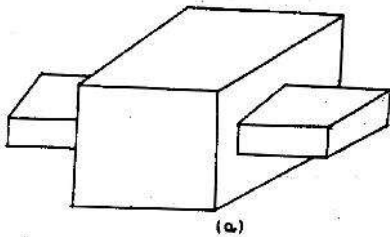

Fig.1.14 Closed pair

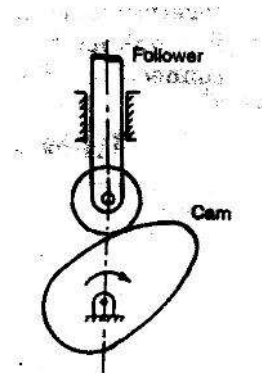

Fig. 1.15 Force closed pair (cam & follower)

**Constrained motion:** In a kinematic pair, if one element has got only one definite motion relative to the other, then the motion is called constrained motion.

- (a) **Completely constrained motion.** If the constrained motion is achieved by the pairing elements themselves, then it is called completely constrained motion.

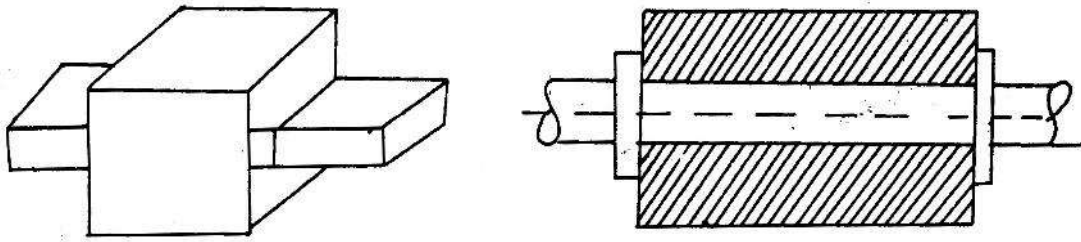

Fig.1.16 Completely constrained motion

**(b) Successfully constrained motion.** If constrained motion is not achieved by the pairing elements themselves, but by some other means, then, it is called successfully constrained motion. Eg. Foot step bearing, where shaft is constrained from moving upwards, by its self weight.

**(c) Incompletely constrained motion.** When relative motion between pairing elements takes place in more than one direction, it is called incompletely constrained motion. Eg. Shaft in a circular hole.

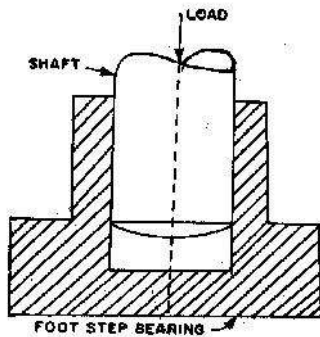

Fig.1.17 Foot step bearing

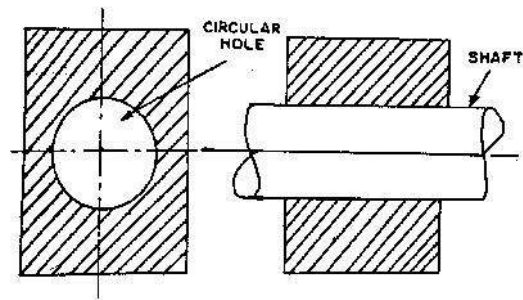

Fig.1.18 Incompletely constrained motion

**Kinematic chain:** A kinematic chain is a group of links either joined together or arranged in a manner that permits them to move relative to one another. If the links are connected in such a way that no motion is possible, it results in a locked chain or structure.

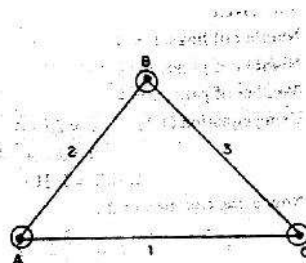

Fig.1.19 Locked chain or structure

**Mechanism:** A mechanism is a constrained kinematic chain. This means that the motion of any one link in the kinematic chain will give a definite and predictable motion relative to each of the others. Usually one of the links of the kinematic chain is fixed in a mechanism.

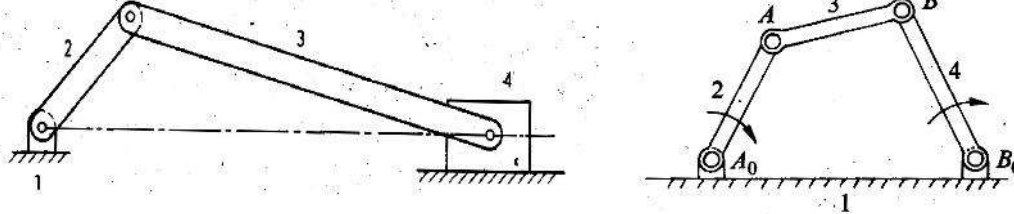

Fig.1.20 Slider crank and four bar mechanisms.

If, for a particular position of a link of the chain, the positions of each of the other links of the chain can not be predicted, then it is called as unconstrained kinematic chain and it is not mechanism.

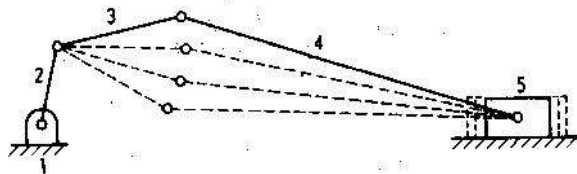

Fig.1.21 Unconstrained kinematic chain

**Machine:** A machine is a mechanism or collection of mechanisms, which transmit force from the source of power to the resistance to be overcome. Though all machines are mechanisms, all mechanisms are not machines. Many instruments are mechanisms but are not machines, because they do no useful work nor do they transform energy. Eg. Mechanical clock, drafter.

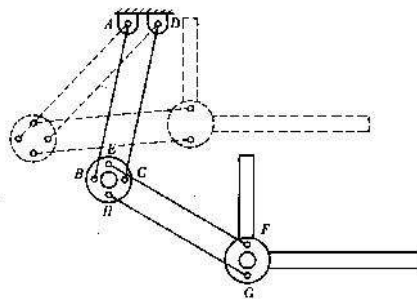

Fig.1.21 Drafter

**Planar mechanisms:** When all the links of a mechanism have plane motion, it is called as a planar mechanism. All the links in a planar mechanism move in planes parallel to the reference plane.

**Degrees of freedom/mobility of a mechanism:** It is the number of inputs (number of independent coordinates) required to describe the configuration or position of all the links of the mechanism, with respect to the fixed link at any given instant.

**Grubler's equation:** Number of degrees of freedom of a mechanism is given by

$$F = 3(n-1) - 2l - h. \text{ Where,}$$

F = Degrees of freedom

n = Number of links =  $n_2 + n_3 + \dots + n_j$ , where,  $n_2$  = number of binary links,  $n_3$  = number of ternary links...etc.

l = Number of lower pairs, which is obtained by counting the number of joints. If more than two links are joined together at any point, then, one additional lower pair is to be considered for every additional link.

h = Number of higher pairs

**Examples of determination of degrees of freedom of planar mechanisms:**

(i)

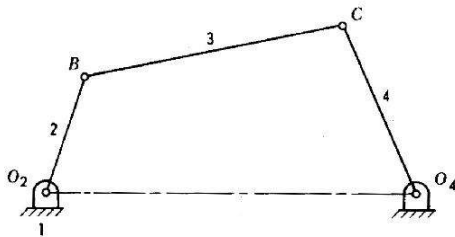

$$F = 3(n-1) - 2l - h$$

Here,  $n_2 = 4$ ,  $n = 4$ ,  $l = 4$  and  $h = 0$ .

$$F = 3(4-1) - 2(4) = 1$$

I.e., one input to any one link will result in definite motion of all the links.

(ii)

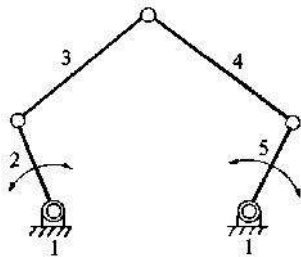

$$F = 3(n-1) - 2l - h$$

Here,  $n_2 = 5$ ,  $n = 5$ ,  $l = 5$  and  $h = 0$ .

$$F = 3(5-1) - 2(5) = 2$$

I.e., two inputs to any two links are required to yield definite motions in all the links.

(iii)

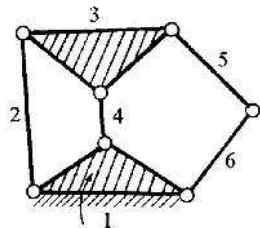

$$F = 3(n-1) - 2l - h$$

Here,  $n_2 = 4$ ,  $n_3 = 2$ ,  $n = 6$ ,  $l = 7$  and  $h = 0$ .

$$F = 3(6-1) - 2(7) = 1$$

I.e., one input to any one link will result in definite motion of all the links.

(iv)

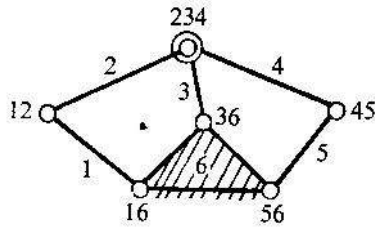

$$F = 3(n-1) - 2l - h$$

Here,  $n_2 = 5$ ,  $n_3 = 1$ ,  $n = 6$ ,  $l = 7$  (at the intersection of 2, 3 and 4, two lower pairs are to be considered) and  $h = 0$ .

$$F = 3(6-1) - 2(7) = 1$$

(v)

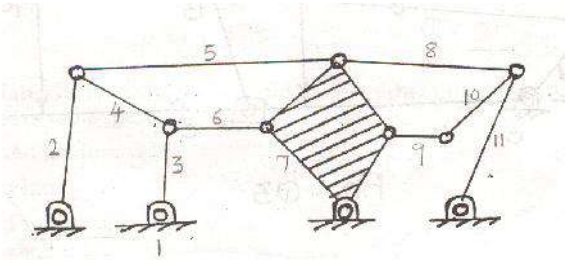

$$F = 3(n-1) - 2l - h$$

Here,  $n = 11$ ,  $l = 15$  (two lower pairs at the intersection of 3, 4, 6; 2, 4, 5; 5, 7, 8; 8, 10, 11) and  $h = 0$ .

$$F = 3(11-1) - 2(15) = 0$$

(vi) Determine the mobility of the following mechanisms.

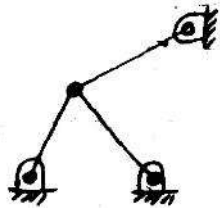

(a)

$$F = 3(n-1) - 2l - h$$

Here,  $n = 4$ ,  $l = 5$  and  $h = 0$ .

$$F = 3(4-1) - 2(5) = -1$$

I.e., it is a structure



(b)

$$F = 3(n-1) - 2l - h$$

Here,  $n = 3$ ,  $l = 2$  and  $h = 1$ .

$$F = 3(3-1) - 2(2) - 1 = 1$$

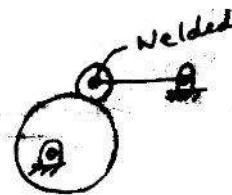

(c)

$$F = 3(n-1) - 2l - h$$

Here,  $n = 3$ ,  $l = 2$  and  $h = 1$ .

$$F = 3(3-1) - 2(2) - 1 = 1$$

**Inversions of mechanism:** A mechanism is one in which one of the links of a kinematic chain is fixed. Different mechanisms can be obtained by fixing different links of the same kinematic chain. These are called as inversions of the mechanism. By changing the fixed link, the number of mechanisms which can be obtained is equal to the number of links. Excepting the original mechanism, all other mechanisms will be known as inversions of original mechanism. The inversion of a mechanism does not change the motion of its links relative to each other.

**Four bar chain:**

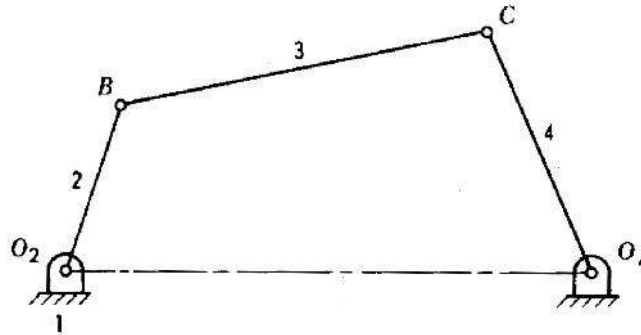

Fig 1.22 Four bar chain

One of the most useful and most common mechanisms is the four-bar linkage. In this mechanism, the link which can make complete rotation is known as crank (link 2). The link which oscillates is known as rocker or lever (link 4). And the link connecting these two is known as coupler (link 3). Link 1 is the frame.

**Inversions of four bar chain:**

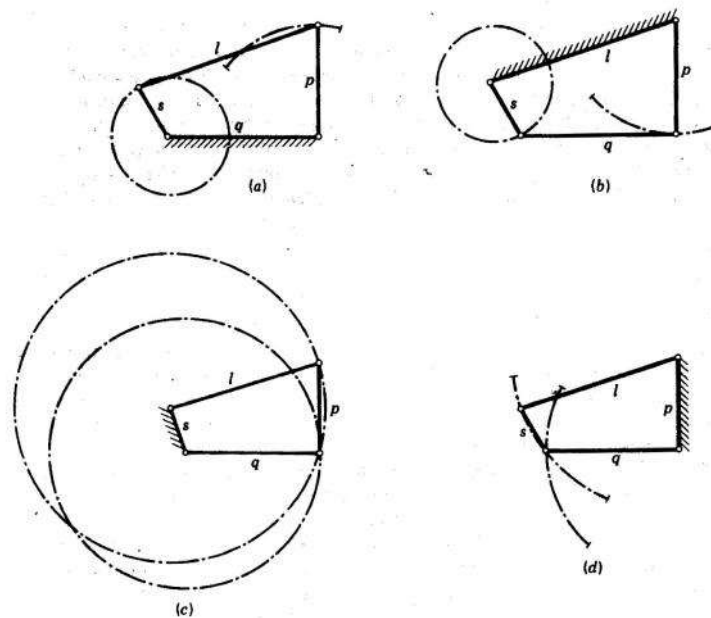

Fig.1.23 Inversions of four bar chain.

**Crank-rocker mechanism:** In this mechanism, either link 1 or link 3 is fixed. Link 2 (crank) rotates completely and link 4 (rocker) oscillates. It is similar to (a) or (b) of fig.1.23.

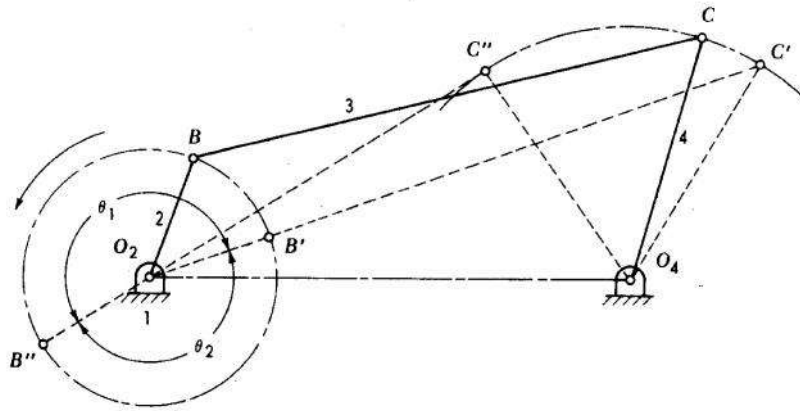

Fig.1.24

**Drag link mechanism.** Here link 2 is fixed and both links 1 and 4 make complete rotation but with different velocities. This is similar to 1.23(c).

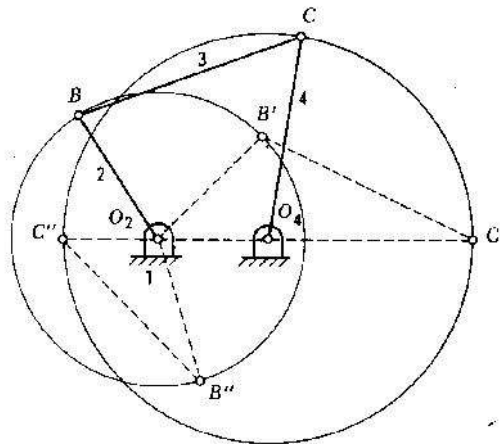

Fig.1.25

**Double crank mechanism.** This is one type of drag link mechanism, where, links 1 & 3 are equal and parallel and links 2 & 4 are equal and parallel.

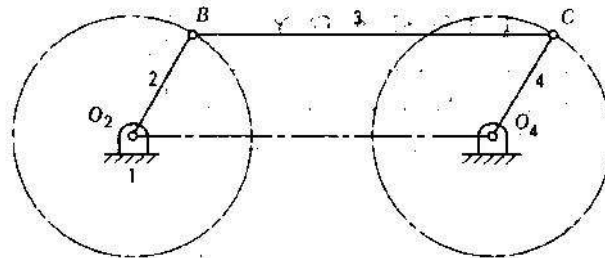

Fig.1.26

**Double rocker mechanism.** In this mechanism, link 4 is fixed. Link 2 makes complete rotation, whereas links 3 & 4 oscillate (Fig.1.23d)

**Slider crank chain:** This is a kinematic chain having four links. It has one sliding pair and three turning pairs. Link 2 has rotary motion and is called crank. Link 3 has got combined rotary and reciprocating motion and is called connecting rod. Link 4 has reciprocating motion and is called slider. Link 1 is frame (fixed). This mechanism is used to convert rotary motion to reciprocating and vice versa.

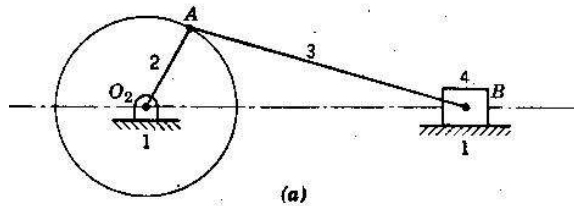
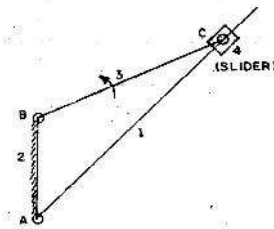
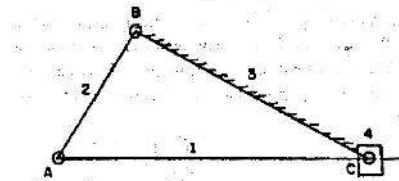

Fig1.27

**Inversions of slider crank chain:** Inversions of slider crank mechanism is obtained by fixing links 2, 3 and 4.



(a) crank fixed



(b) connecting rod fixed

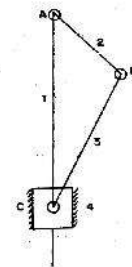

(c) slider fixed

Fig.1.28

**Rotary engine – I inversion of slider crank mechanism. (crank fixed)**

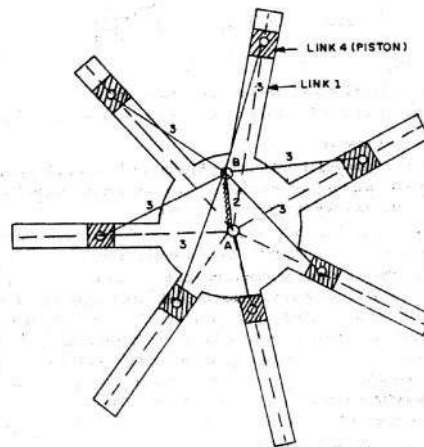

Fig.1.29

**Whitworth quick return motion mechanism–I inversion of slider crank mechanism.**

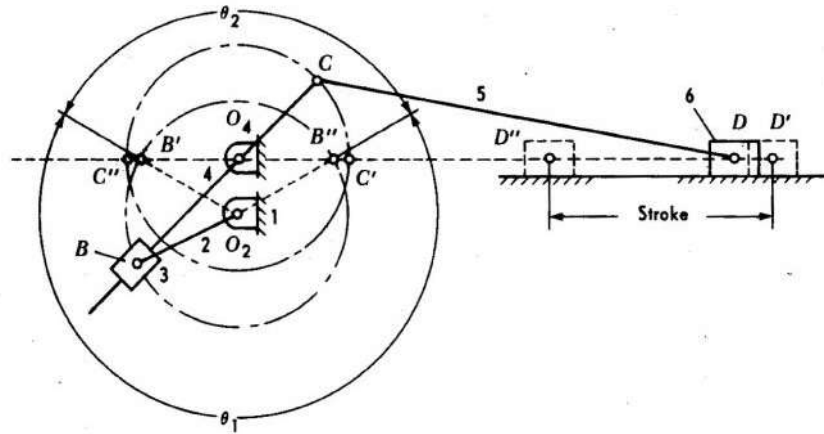

Fig.1.30

**Crank and slotted lever quick return motion mechanism – II inversion of slider crank mechanism (connecting rod fixed).**

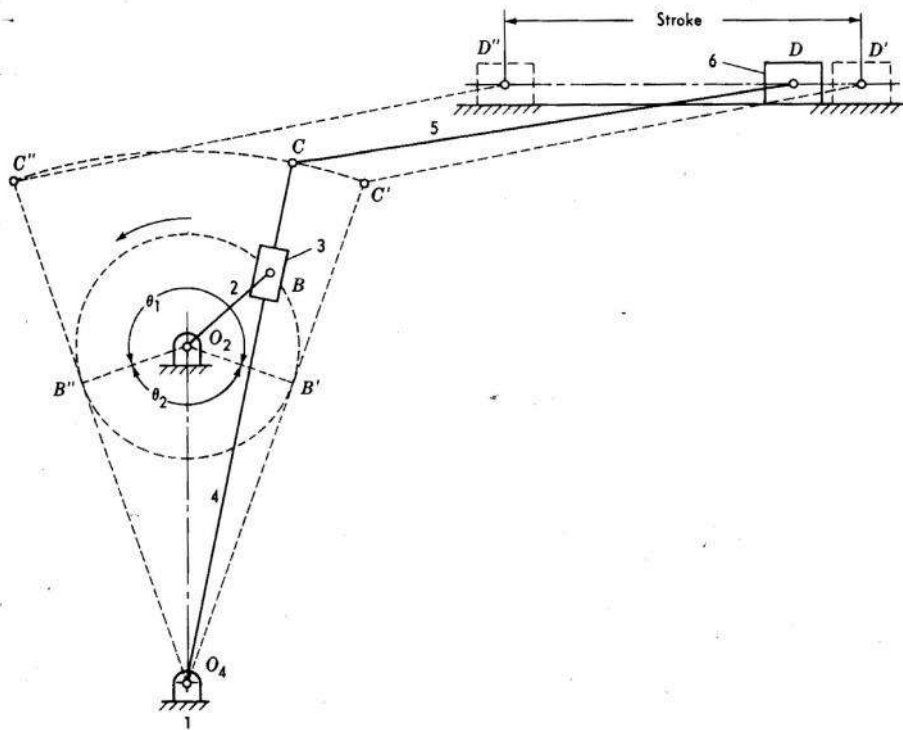

Fig.1.31

Oscillating cylinder engine–II inversion of slider crank mechanism (connecting rod fixed).

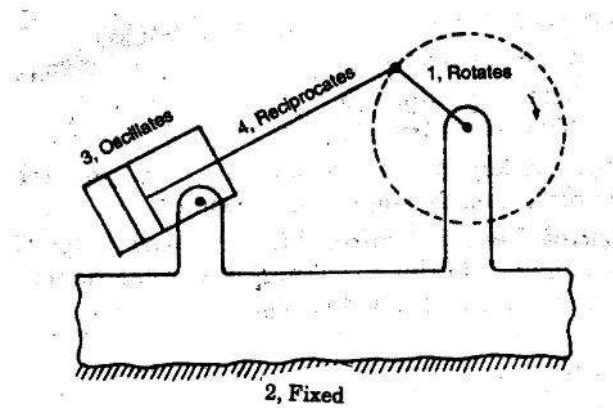

Fig.1.32

Pendulum pump or bull engine–III inversion of slider crank mechanism (slider fixed).

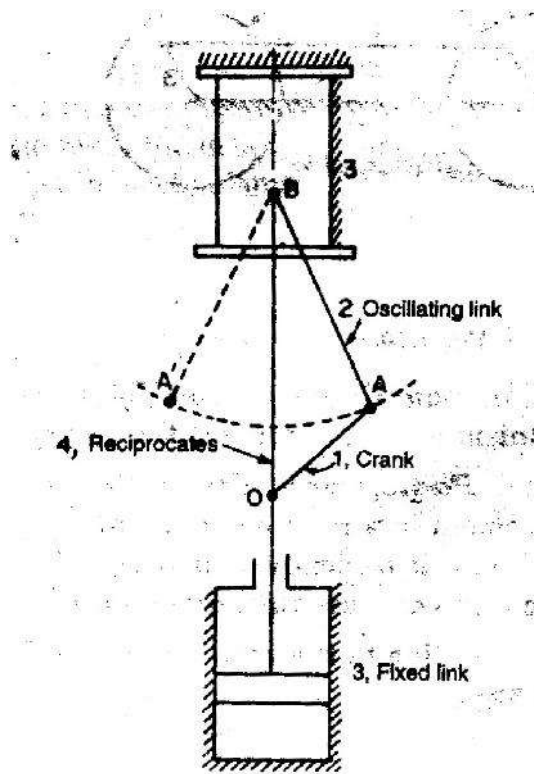

Fig.1.33

**Double slider crank chain:** It is a kinematic chain consisting of two turning pairs and two sliding pairs.

**Scotch –Yoke mechanism.**

Turning pairs – 1&2, 2&3; Sliding pairs – 3&4, 4&1.

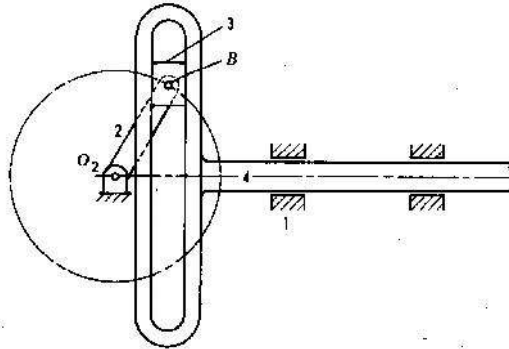

Fig.1.34

**Inversions of double slider crank mechanism:**

**Elliptical trammel.** This is a device which is used for generating an elliptical profile.

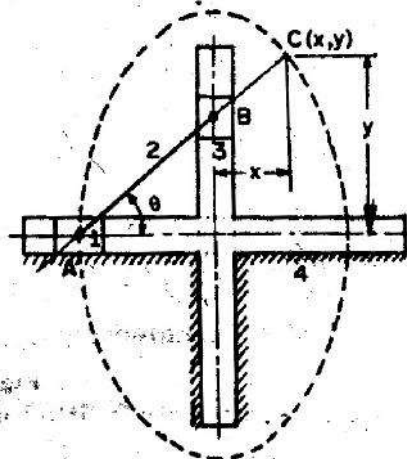

Fig.1.35

In fig. 1.35, if  $AC = p$  and  $BC = q$ , then,  $x = q \cdot \cos \theta$  and  $y = p \cdot \sin \theta$ .

Rearranging,  $\left(\frac{x}{q}\right)^2 + \left(\frac{y}{p}\right)^2 = \cos^2 \theta + \sin^2 \theta = 1$ . This is the equation of an ellipse. The path traced by point C is an ellipse, with major axis and minor axis equal to  $2p$  and  $2q$  respectively.

**Oldham coupling.** This is an inversion of double slider crank mechanism, which is used to connect two parallel shafts, whose axes are offset by a small amount.

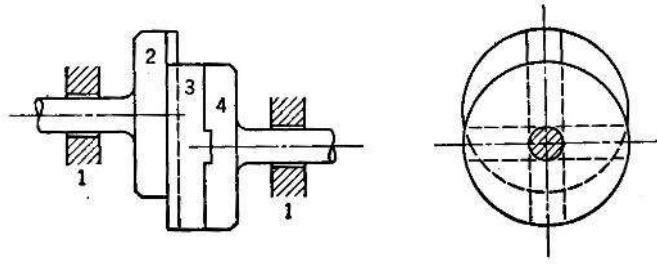

Fig.1.36

**References:**

1. **Theory of Machines and Mechanisms** by Joseph Edward Shigley and John Joseph Uicker, Jr. *McGraw-Hill International Editions.*
2. **Kinematics and Dynamics of Machines** by George H. Martin. *McGraw-Hill Publications.*
3. **Mechanisms and Dynamics of Machinery** by Hamilton H. Mabie and Fred W. Ocvirk. *John Wiley and Sons.*
4. **Theory of Machines** by V.P. Singh. *Dhanpat Rai and Co.*
5. **The Theory of Machines through solved problems** by J.S. Rao. *New age international publishers.*
6. **A text book of Theory of Machines** by Dr. R.K. Bansal. *Laxmi Publications (P) Ltd.*

# Kinematics of Machines

## CHAPTER – I (contd.)

### Quick return motion mechanisms.

Quick return mechanisms are used in machine tools such as shapers and power driven saws for the purpose of giving the reciprocating cutting tool a slow cutting stroke and a quick return stroke with a constant angular velocity of the driving crank. Some of the common types of quick return motion mechanisms are discussed below. The ratio of time required for the cutting stroke to the time required for the return stroke is called the time ratio and is greater than unity.

### Drag link mechanism

This is one of the inversions of four bar mechanism, with four turning pairs. Here, link 2 is the input link, moving with constant angular velocity in anti-clockwise direction. Point C of the mechanism is connected to the tool post E of the machine. During cutting stroke, tool post moves from E<sub>1</sub> to E<sub>2</sub>. The corresponding positions of C are C<sub>1</sub> and C<sub>2</sub> as shown in the fig. 1.37. For the point C to move from C<sub>1</sub> to C<sub>2</sub>, point B moves from B<sub>1</sub> to B<sub>2</sub>, in anti-clockwise direction. IE, cutting stroke takes place when input link moves through angle B<sub>1</sub>AB<sub>2</sub> in anti-clockwise direction and return stroke takes place when input link moves through angle B<sub>2</sub>AB<sub>1</sub> in anti-clockwise direction.

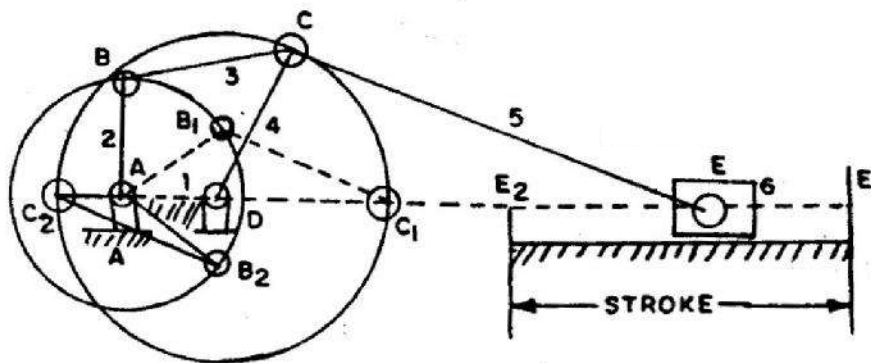

Fig.1.37

The time ratio is given by the following equation.

$$\frac{\text{Time for forward stroke}}{\text{Time for return stroke}} = \frac{B_1 \hat{A} B_2 (\text{anti-clockwise})}{B_2 \hat{A} B_1 (\text{anti-clockwise})}$$

### Whitworth quick return motion mechanism:

This is first inversion of slider mechanism, where, crank 1 is fixed. Input is given to link 2, which moves at constant speed. Point C of the mechanism is connected to the tool post

D of the machine. During cutting stroke, tool post moves from  $D^1$  to  $D^{11}$ . The corresponding positions of C are  $C^1$  and  $C^{11}$  as shown in the fig. 1.38. For the point C to move from  $C^1$  to  $C^{11}$ , point B moves from  $B^1$  to  $B^{11}$ , in anti-clockwise direction. I.E., cutting stroke takes place when input link moves through angle  $B^1O_2B^{11}$  in anti-clockwise direction and return stroke takes place when input link moves through angle  $B^{11}O_2B^1$  in anti-clockwise direction.

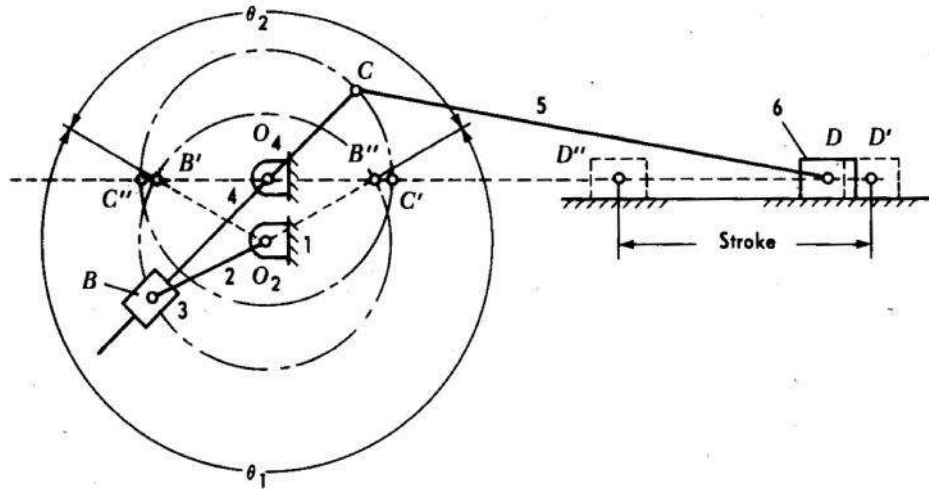

Fig.1.38

The time ratio is given by the following equation.

$$\frac{\text{Time for forward stroke}}{\text{Time for return stroke}} = \frac{B'O_2B''}{B''O_2B'} = \frac{\theta_1}{\theta_2}$$

### Crank and slotted lever quick return motion mechanism

This is second inversion of slider mechanism, where, connecting rod is fixed. Input is given to link 2, which moves at constant speed. Point C of the mechanism is connected to the tool post D of the machine. During cutting stroke, tool post moves from  $D^1$  to  $D^{11}$ . The corresponding positions of C are  $C^1$  and  $C^{11}$  as shown in the fig. 1.39. For the point C to move from  $C^1$  to  $C^{11}$ , point B moves from  $B^1$  to  $B^{11}$ , in anti-clockwise direction. I.E., cutting stroke takes place when input link moves through angle  $B^1O_2B^{11}$  in anti-clockwise direction and return stroke takes place when input link moves through angle  $B^{11}O_2B^1$  in anti-clockwise direction.

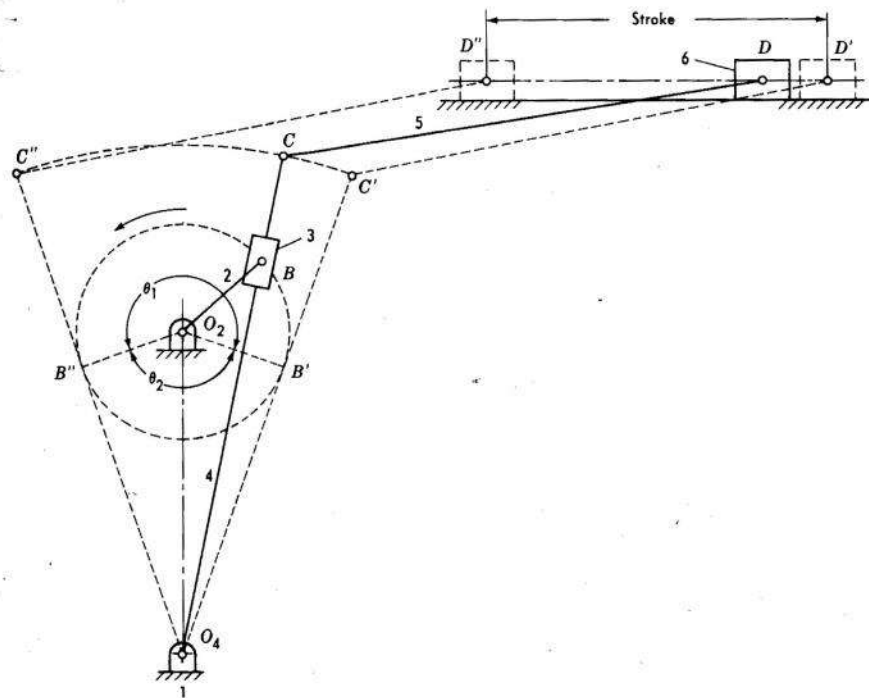

Fig. 1.39

The time ratio is given by the following equation.

$$\frac{\text{Time for forward stroke}}{\text{Time for return stroke}} = \frac{B'\hat{O}_2B''}{B''\hat{O}_2B'} = \frac{\theta_1}{\theta_2}$$

### Straight line motion mechanisms

Straight line motion mechanisms are mechanisms, having a point that moves along a straight line, or nearly along a straight line, without being guided by a plane surface.

#### Condition for exact straight line motion:

If point B (fig. 1.40) moves on the circumference of a circle with center O and radius OA, then, point C, which is an extension of AB traces a straight line perpendicular to AO, provided product of AB and AC is constant.

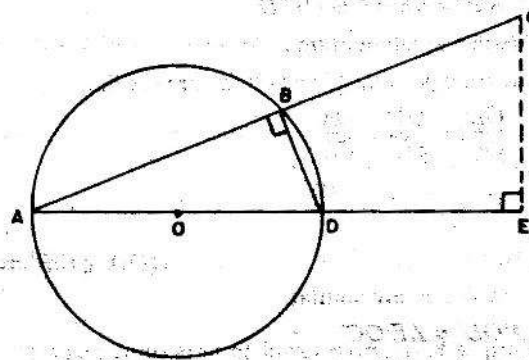

Fig.1.40

Locus of pt.C will be a straight line, to AE if,  $AB \times AC$  is constant

**Proof:**

$$\triangle AEC \cong \triangle ABD$$

$$\therefore \frac{AD}{AC} = \frac{AB}{AE}$$

$$\therefore AE = \frac{AB \times AC}{AD}$$

but  $AD = \text{const.}$

$\therefore AE = \text{const.}, \text{ if } AB \times AC = \text{const.}$

**Peaucellier exact straight line motion mechanism:**

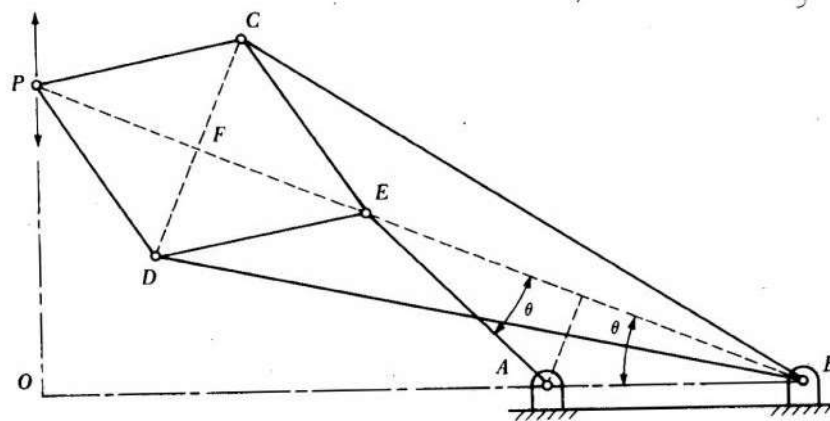

Fig.1.41

Here, AE is the input link and point E moves along a circular path of radius  $AE = AB$ . Also,  $EC = ED = PC = PD$  and  $BC = BD$ . Point P of the mechanism moves along exact straight line, perpendicular to BA extended.

To prove B, E and P lie on same straight line:

Triangles BCD, ECD and PCD are all isosceles triangles having common base CD and apex points being B, E and P. Therefore points B, E and P always lie on the perpendicular bisector of CD. Hence these three points always lie on the same straight line.

To prove product of BE and BP is constant.

In triangles BFC and PFC,

$$BC^2 = FB^2 + FC^2 \text{ and } PC^2 = PF^2 + FC^2$$

$$\therefore BC^2 - PC^2 = FB^2 - PF^2 = (FB + PF)(FB - PF) = BP \times BE$$

But since BC and PC are constants, product of BP and BE is constant, which is the condition for exact straight line motion. Thus point P always moves along a straight line perpendicular to BA as shown in the fig.1.41.

**Approximate straight line motion mechanism:** A few four bar mechanisms with certain modifications provide approximate straight line motions.

### Robert's mechanism

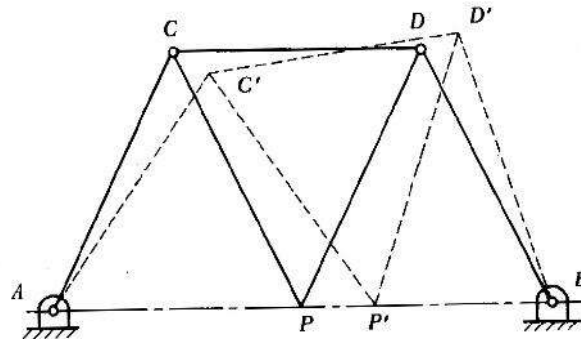

Fig.1.42

This is a four bar mechanism, where, PCD is a single integral link. Also, dimensions AC, BD, CP and PD are all equal. Point P of the mechanism moves very nearly along line AB.

### Intermittent motion mechanisms

An intermittent-motion mechanism is a linkage which converts continuous motion into intermittent motion. These mechanisms are commonly used for indexing in machine tools.

#### Geneva wheel mechanism

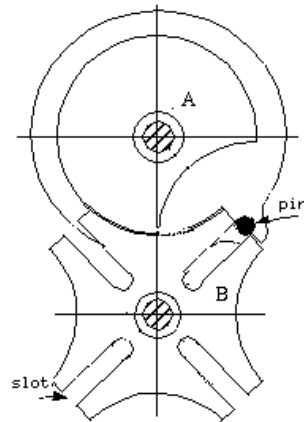

Fig.1.43

In the mechanism shown (Fig.1.43), link A is driver and it contains a pin which engages with the slots in the driven link B. The slots are positioned in such a manner, that the pin enters and leaves them tangentially avoiding impact loading during transmission of motion. In the mechanism shown, the driven member makes one-fourth of a revolution for each revolution of the driver. The locking plate, which is mounted on the driver, prevents the driven member from rotating except during the indexing period.

#### Ratchet and pawl mechanism

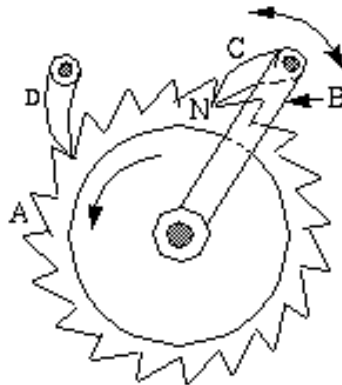

Fig.1.44

Ratchets are used to transform motion of rotation or translation into intermittent rotation or translation. In the fig.1.44, A is the ratchet wheel and C is the pawl. As lever B is made

to oscillate, the ratchet wheel will rotate anticlockwise with an intermittent motion. A holding pawl D is provided to prevent the reverse motion of ratchet wheel.

## Other mechanisms

### Toggle mechanism

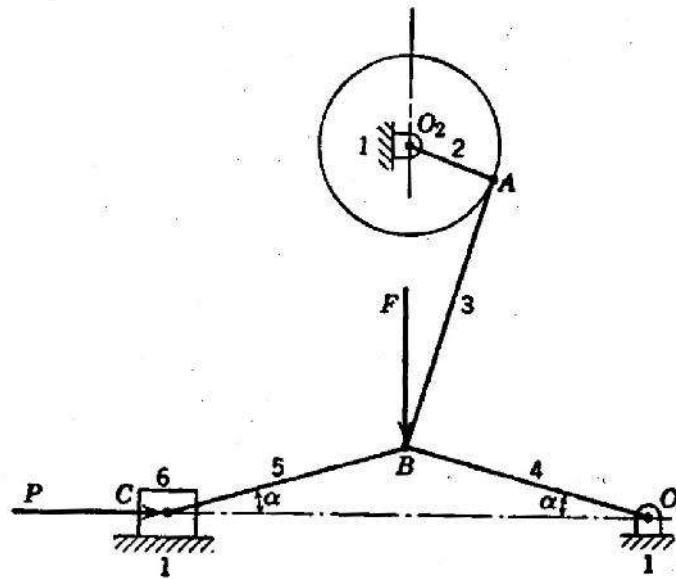

Fig.1.45

Toggle mechanisms are used, where large resistances are to be overcome through short distances. Here, effort applied will be small but acts over large distance. In the mechanism shown in fig.1.45, 2 is the input link, to which, power is supplied and 6 is the output link, which has to overcome external resistance. Links 4 and 5 are of equal length.

Considering the equilibrium condition of slider 6,

$$\tan \alpha = \frac{F/2}{P}$$

$$\therefore F = 2P \tan \alpha$$

For small angles of  $\alpha$ , F (effort) is much smaller than P (resistance).

This mechanism is used in rock crushers, presses, riveting machines etc.

## Pantograph

Pantographs are used for reducing or enlarging drawings and maps. They are also used for guiding cutting tools or torches to fabricate complicated shapes.

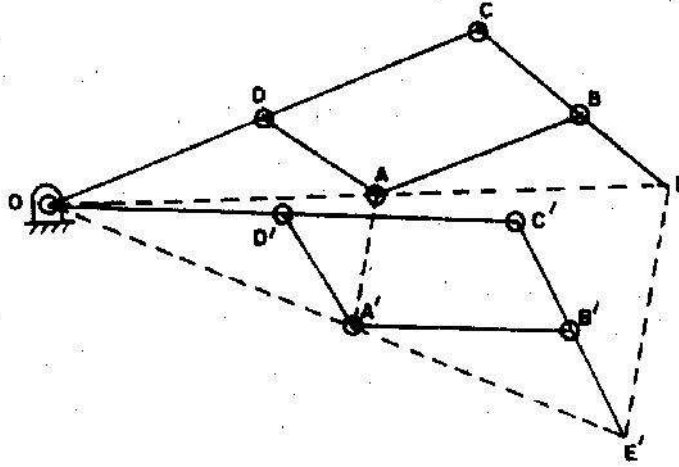

Fig.1.46

In the mechanism shown in fig.1.46 path traced by point A will be magnified by point E to scale, as discussed below.

In the mechanism shown,  $AB = CD$ ;  $AD = BC$  and  $OAE$  lie on a straight line.

When point A moves to  $A'$ , E moves to  $E'$  and  $OA'E'$  also lies on a straight line.

From the fig.1.46,  $\triangle ODA \equiv \triangle OCE$  and  $\triangle OD'A' \equiv \triangle OC'E'$ .

$$\therefore \frac{OD}{OC} = \frac{OA}{OE} = \frac{DA}{CE} \text{ and } \frac{OD'}{OC'} = \frac{OA'}{OE'} = \frac{D'A'}{C'E'}$$

$$\text{But, } \frac{OD}{OC} = \frac{OD'}{OC'}; \therefore \frac{OA}{OE} = \frac{OA'}{OE'}; \therefore \triangle OAA' \equiv \triangle OEE'.$$

$$\therefore EE' \parallel AA'$$

$$\text{And } \frac{EE'}{AA'} = \frac{OE}{OA} = \frac{OC}{OD}$$

$$\therefore EE' = AA' \left( \frac{OC}{OD} \right)$$

Where  $\left( \frac{OC}{OD} \right)$  is the magnification factor.

### Hooke's joint (Universal joints)

Hooke's joints is used to connect two nonparallel but intersecting shafts. In its basic shape, it has two U-shaped yokes 'a' and 'b' and a center block or cross-shaped piece, C. (fig.1.47(a))

The universal joint can transmit power between two shafts intersecting at around  $30^\circ$  angles ( ). However, the angular velocity ratio is not uniform during the cycle of operation. The amount of fluctuation depends on the angle ( ) between the two shafts. For uniform transmission of motion, a pair of universal joints should be used (fig.1.47(b)). Intermediate shaft 3 connects input shaft 1 and output shaft 2 with two universal joints. The angle between 1 and 2 is equal to angle between 2 and 3. When shaft 1 has uniform rotation, shaft 3 varies in speed; however, this variation is compensated by the universal joint between shafts 2 and 3. One of the important applications of universal joint is in automobiles, where it is used to transmit power from engine to the wheel axle.

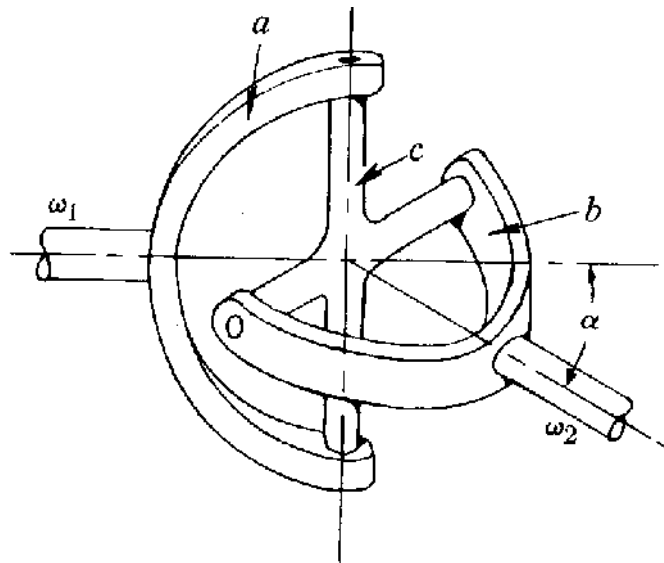

Fig.1.47(a)

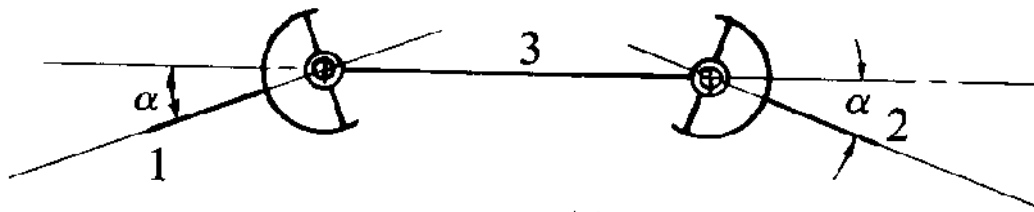

Fig.1.47(b)

### Steering gear mechanism

The steering mechanism is used in automobiles for changing the directions of the wheel axles with reference to the chassis, so as to move the automobile in the desired path.

Usually, the two back wheels will have a common axis, which is fixed in direction with reference to the chassis and the steering is done by means of front wheels.

In automobiles, the front wheels are placed over the front axles (stub axles), which are pivoted at the points A & B as shown in the fig.1.48. When the vehicle takes a turn, the front wheels, along with the stub axles turn about the pivoted points. The back axle and the back wheels remain straight.

Always there should be absolute rolling contact between the wheels and the road surface. Any sliding motion will cause wear of tyres. When a vehicle is taking turn, absolute rolling motion of the wheels on the road surface is possible, only if all the wheels describe concentric circles. Therefore, the two front wheels must turn about the same instantaneous centre I which lies on the axis of the back wheel.

### Condition for perfect steering

The condition for perfect steering is that all the four wheels must turn about the same instantaneous centre. While negotiating a curve, the inner wheel makes a larger turning angle than the angle subtended by the axis of the outer wheel.

In the fig.1.48,  $a$  = wheel track,  $L$  = wheel base,  $w$  = distance between the pivots of front axles.

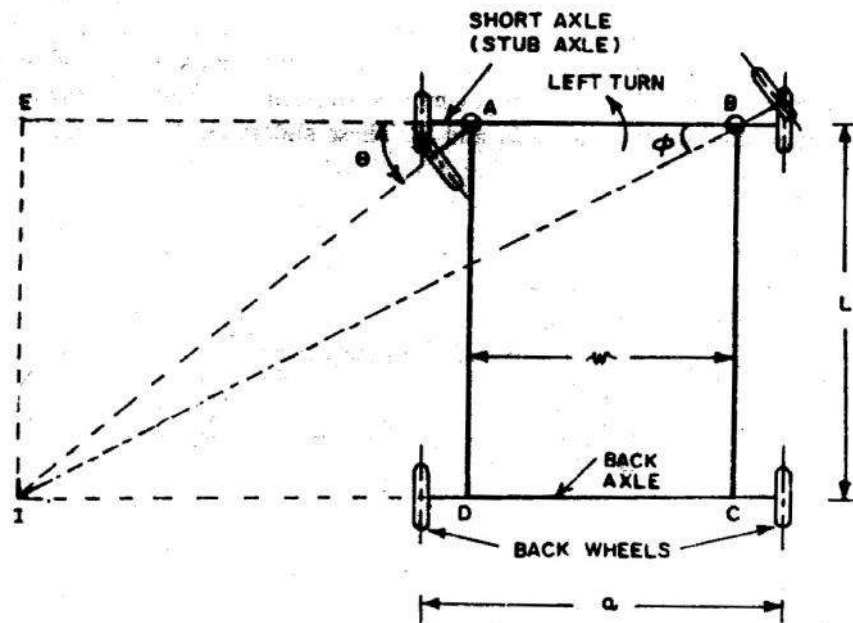

Fig.1.48

$$\text{From } \triangle IAE, \cot \theta = \frac{AE}{EI} = \frac{AE}{L} \text{ and}$$

$$\text{from } \triangle BEI, \cot \theta = \frac{EB}{EI} = \frac{(EA + AB)}{EI} = \frac{(EA + w)}{L} = \frac{EA}{L} + \frac{w}{L} = \cot \theta + \frac{w}{L}$$

$\therefore \cot\phi - \cot\theta = \frac{w}{L}$ . This is the fundamental equation for correct steering. If this condition is satisfied, there will be no skidding of the wheels when the vehicle takes a turn.

### Ackermann steering gear mechanism

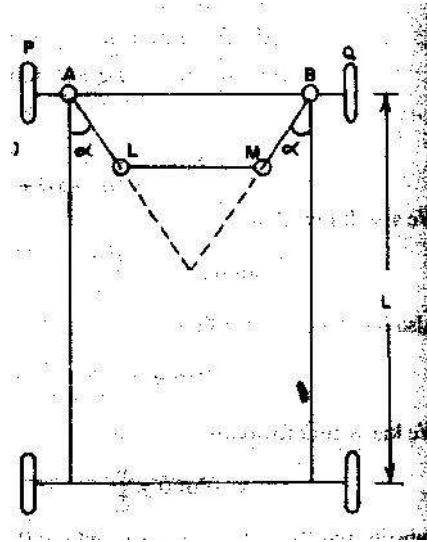

Fig.1.49

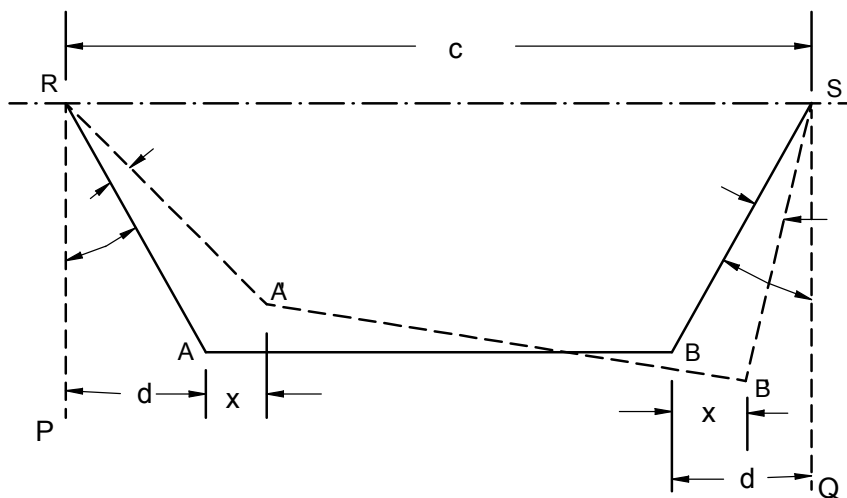

fig.1.50

Ackerman steering mechanism, RSAB is a four bar chain as shown in fig.1.50. Links RA and SB which are equal in length are integral with the stub axles. These links are connected with each other through track rod AB. When the vehicle is in straight ahead position, links RA and SB make equal angles with the center line of the vehicle. The dotted lines in fig.1.50 indicate the position of the mechanism when the vehicle is turning left.

Let  $AB=l$ ,  $RA=SB=r$ ;  $P\hat{R}A = Q\hat{S}B = \alpha$  and in the turned position,  $A\hat{R}A^1 = \theta$  &  $B\hat{S}B^1 = \phi$ . IE, the stub axles of inner and outer wheels turn by  $\theta$  and  $\phi$  angles respectively.

Neglecting the obliquity of the track rod in the turned position, the movements of A and B in the horizontal direction may be taken to be same (x).

Then,  $\sin(\alpha + \theta) = \frac{d+x}{r}$  and  $\sin(\alpha - \phi) = \frac{d-x}{r}$

$$\text{Adding, } \sin(\alpha + \theta) + \sin(\alpha - \phi) = \frac{2d}{r} = 2 \sin \alpha \quad [1]$$

Angle  $\theta$  can be determined using the above equation. The values of  $\theta$  and  $\phi$  to be taken in this equation are those found for correct steering using the equation  $\cot \phi - \cot \theta = \frac{w}{L}$ . [2]

This mechanism gives correct steering in only three positions. One, when  $\theta = 0$  and other two each corresponding to the turn to right or left (at a fixed turning angle, as determined by equation [1]).

The correct values of  $\theta$ ,  $[\theta_c]$  corresponding to different values of  $\phi$ , for correct steering can be determined using equation [2]. For the given dimensions of the mechanism, actual values of  $\theta$ ,  $[\theta_a]$  can be obtained for different values of  $\phi$ . The difference between  $\theta_c$  and  $\theta_a$  will be very small for small angles of  $\phi$ , but the difference will be substantial, for larger values of  $\phi$ . Such a difference will reduce the life of tyres because of greater wear on account of slipping.

But for larger values of  $\phi$ , the automobile must take a sharp turn; hence it will be moving at a slow speed. At low speeds, wear of the tyres is less. Therefore, the greater difference between  $\theta_c$  and  $\theta_a$  for larger values of  $\phi$  will not matter.

As this mechanism employs only turning pairs, friction and wear in the mechanism will be less. Hence its maintenance will be easier and is commonly employed in automobiles.

### References:

1. **Theory of Machines and Mechanisms** by Joseph Edward Shigley and John Joseph Uicker, Jr. *McGraw-Hill International Editions*.
2. **Kinematics and Dynamics of Machines** by George H. Martin. *McGraw-Hill Publications*.
3. **Mechanisms and Dynamics of Machinery** by Hamilton H. Mabie and Fred W. Ocvirk. *John Wiley and Sons*.
4. **Theory of Machines** by V.P. Singh. *Dhanpat Rai and Co*.
5. **The Theory of Machines through solved problems** by J.S. Rao. *New age international publishers*.
6. **A text book of Theory of Machines** by Dr. R.K. Bansal. *Laxmi Publications (P) Ltd*.

**Subject: KINEMATICS OF MACHINES**  
**Topic: VELOCITY AND ACCELERATION**

• **Introduction**

Kinematics deals with study of relative motion between the various parts of the machines. Kinematics does not involve study of forces. Thus motion leads study of displacement, velocity and acceleration of a part of the machine.

Study of Motions of various parts of a machine is important for determining their velocities and accelerations at different moments.

As dynamic forces are a function of acceleration and acceleration is a function of velocities, study of velocity and acceleration will be useful in the design of mechanism of a machine. The mechanism will be represented by a line diagram which is known as configuration diagram. The analysis can be carried out both by graphical method as well as analytical method.

• **Some important Definitions**

**Displacement:** All particles of a body move in parallel planes and travel by same distance is known, linear displacement and is denoted by 'x'.

A body rotating about a fixed point in such a way that all particles move in circular path angular displacement and is denoted by 'θ'.

**Velocity:** Rate of change of displacement is velocity. Velocity can be linear velocity or angular velocity.

$$\text{Linear velocity is Rate of change of linear displacement} = V = \frac{dx}{dt}$$

$$\text{Angular velocity is Rate of change of angular displacement} = \omega = \frac{d\theta}{dt}$$

Relation between linear velocity and angular velocity.

$$x = r\theta$$

$$\frac{dx}{dt} = r \frac{d\theta}{dt}$$

$$V = r\omega$$

$$\omega = \frac{d\theta}{dt}$$

**Acceleration:** Rate of change of velocity

$$f = \frac{dv}{dt} = \frac{d^2x}{dt^2} \text{ Linear Acceleration (Rate of change of linear velocity)}$$

$$\text{Thirdly } \alpha = \frac{d\omega}{dt} = \frac{d^2\theta}{dt^2} \text{ Angular Acceleration (Rate of change of angular velocity)}$$

We also have,

**Absolute velocity:** Velocity of a point with respect to a fixed point (zero velocity point).

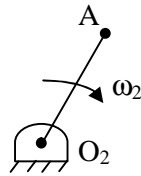

$$V_a = \omega_2 \times r$$

$$V_a = \omega_2 \times O_2 A$$

Ex:  $V_{ao_2}$  is absolute velocity.

**Relative velocity:** Velocity of a point with respect to another point 'x'

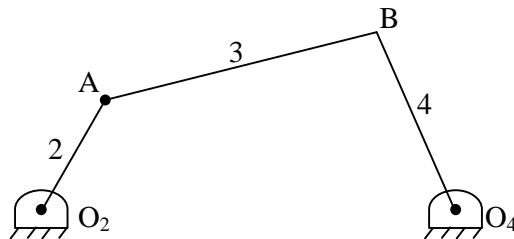

Ex:  $V_{ba} \rightarrow$  Velocity of point B with respect to A

Note: Capital letters are used for configuration diagram. Small letters are used for velocity vector diagram.

This is absolute velocity

$\therefore$  Velocity of point A with respect to  $O_2$  fixed point, zero velocity point.

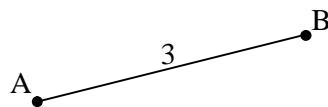

$$V_{ba} = \text{or } V_{ab}$$

$V_{ba} = \text{or } V_{ab}$  Equal in magnitude but opposite in direction.

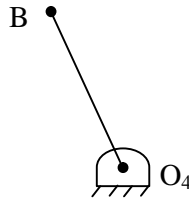

$V_b \rightarrow$  Absolute velocity is velocity of B with respect to  $O_4$  (fixed point, zero velocity point)

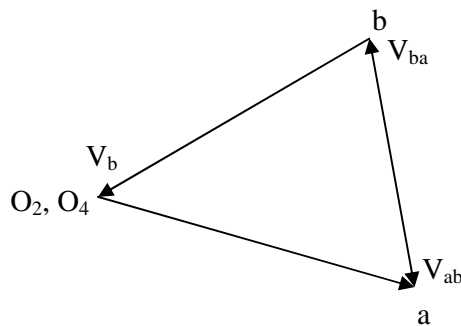

**Velocity vector diagram**

Vector  $\overrightarrow{O_2 a} = V_a =$  Absolute velocity

Vector  $\left. \begin{array}{l} \overrightarrow{ab} = V_{ab} \\ \overrightarrow{ba} = V_a \end{array} \right\}$  Relative velocity

$V_{ab}$  is equal magnitude with  $V_{ba}$  but is opposite in direction.

Vector  $\overrightarrow{O_4 b} = V_b$  absolute velocity.

To illustrate the difference between absolute velocity and relative velocity. Let, us consider a simple situation.

A link AB moving in a vertical plane such that the link is inclined at  $30^\circ$  to the horizontal with point A is moving horizontally at 4 m/s and point B moving vertically upwards. Find velocity of B.

$V_a = 4 \text{ m/s}$   $\vec{ab}$  Absolute velocity Horizontal direction  
(known in magnitude and directors)

$V_b = ?$   $\vec{ab}$  Absolute velocity Vertical direction  
(known in directors only)

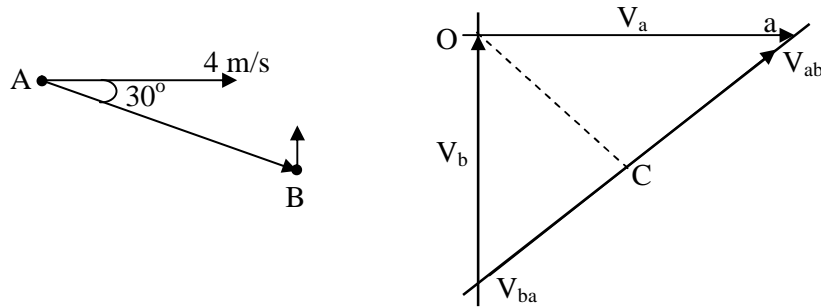

Velocity of B with respect to A is equal in magnitude to velocity of A with respect to B but opposite in direction.

• **Relative Velocity Equation**

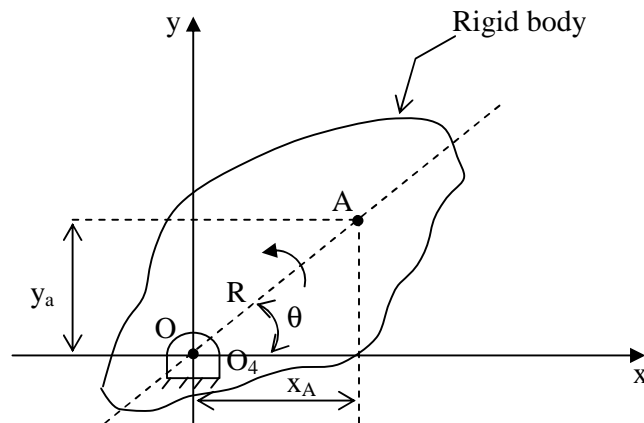

**Fig. 1 Point O is fixed and End A is a point on rigid body.**

Rotation of a rigid link about a fixed centre.

Consider rigid link rotating about a fixed centre O, as shown in figure. The distance between O and A is R and OA makes an angle 'θ' with x-axis next link  $x_A = R \cos \theta, y_A = R \sin \theta$ .

Differentiating  $x_A$  with respect to time gives velocity.

$$\begin{aligned}\frac{d_{x_A}}{dt} &= R(-\sin \theta) \frac{d\theta}{dt} \\ &= -R\omega \sin \theta\end{aligned}$$

Similarly,  $\frac{dy_A}{dt} = R(-\cos \theta) \frac{d\theta}{dt}$   
 $= -R\omega \cos \theta$

Let,  $\frac{d_{x_A}}{dt} = V_A^x$        $\frac{d_{y_A}}{dt} = V_A^y$   
 $\omega = \frac{d}{dt} = \text{angular velocity of OA}$

$$\therefore V_A^x = -R \sin \theta$$

$$V_A^y = -R \cos \theta$$

$\therefore$  Total velocity of point A is given by

$$V_A = \sqrt{(-R\omega \sin \theta)^2 + (-R\omega \cos \theta)^2}$$

$$V_A = R$$

- **Relative Velocity Equation of Two Points on a Rigid link**

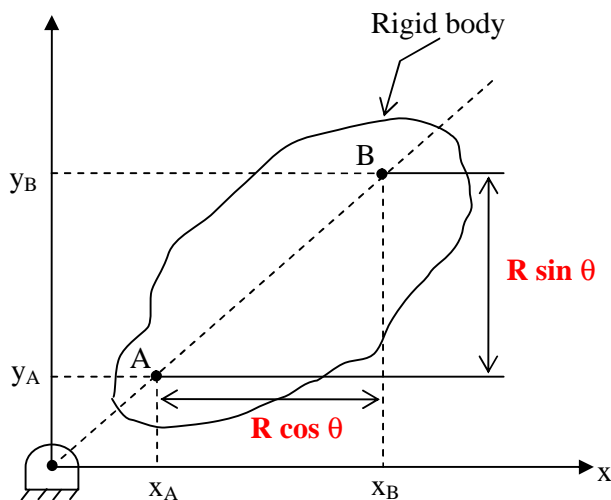

**Fig. 2 Points A and B are located on rigid body**

From Fig. 2

$$x_B = x_A + R \cos \theta \quad y_B = y_A + R \sin \theta$$

Differentiating  $x_B$  and  $y_B$  with respect to time

we get,

$$\begin{aligned} \frac{d_{x_B}}{dt} = V_B^x &= \frac{d_{x_A}}{dt} + R(-\sin \theta) \frac{d\theta}{dt} \\ &= \frac{d_{x_A}}{dt} + R\omega \sin \theta = V_A^x - R\omega \sin \theta \end{aligned}$$

Similarly,

$$\begin{aligned} \frac{d_{y_B}}{dt} = V_B^y &= \frac{d_{y_A}}{dt} + R(\cos \theta) \frac{d\theta}{dt} \\ &= \frac{d_{y_A}}{dt} + R\omega \cos \theta = V_A^y + R\omega \cos \theta \end{aligned}$$

$$V_A = V_A^x \rightarrow V_A^y = \text{Total velocity of point A}$$

Similarly,

$$V_B = V_B^x \rightarrow V_B^y = \text{Total velocity of point B}$$

$$= V_A^x \rightarrow (R \sin \theta) \rightarrow V_A^y \rightarrow R \cos \theta$$

$$= (V_A^x \rightarrow V_A^y) \rightarrow (R \sin \theta + R \cos \theta)$$

$$= (V_A^x \rightarrow V_A^y) V_A \text{ Similarly, } (R \sin \theta + R \cos \theta) = R$$

$$\therefore V_B = V_A \rightarrow R = V_A \rightarrow V_{BA}$$

$$\therefore V_{BA} = V_B - V_A$$

Velocity analysis of any mechanism can be carried out by various methods.

1. By graphical method
2. By relative velocity method
3. By instantaneous method

- **By Graphical Method**

The following points are to be considered while solving problems by this method.

1. Draw the configuration design to a suitable scale.
2. Locate all fixed point in a mechanism as a common point in velocity diagram.
3. Choose a suitable scale for the vector diagram velocity.
4. The velocity vector of each rotating link is  $\perp^r$  to the link.
5. Velocity of each link in mechanism has both magnitude and direction. Start from a point whose magnitude and direction is known.
6. The points of the velocity diagram are indicated by small letters.

*To explain the method let us take a few specific examples.*

1. Four – Bar Mechanism: In a four bar chain ABCD link AD is fixed and is 15 cm long. The crank AB is 4 cm long rotates at 180 rpm (cw) while link CD rotates about D is 8 cm long BC = AD and  $\angle BAD = 60^\circ$ . Find angular velocity of link CD.

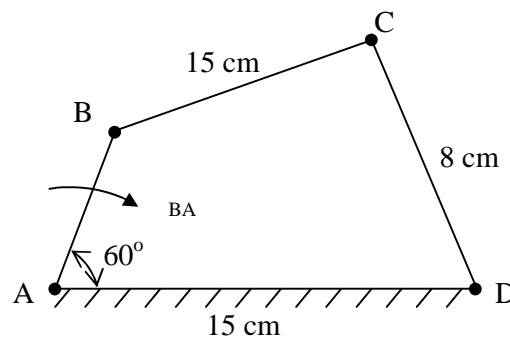

**Configuration Diagram**

Velocity vector diagram

$$V_b = \omega r = \omega_{ba} \times AB = \frac{2\pi \times 120}{60} \times 4 = 50.24 \text{ cm/sec}$$

Choose a suitable scale

$$1 \text{ cm} = 20 \text{ m/s} = \overrightarrow{ab}$$

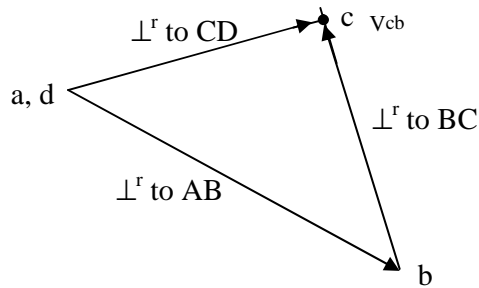

$$V_{cb} = \vec{bc}$$

$$V_c = \vec{dc} = 38 \text{ cm/sec} = V_{cd}$$

We know that  $V = R$

$$V_{cd} = \omega_{CD} \times CD$$

$$\omega_{CD} = \frac{V_{cd}}{CD} = \frac{38}{8} = 4.75 \text{ rad/sec (cw)}$$

2. *Slider Crank Mechanism:*

In a crank and slotted lever mechanism crank rotates of 300 rpm in a counter clockwise direction. Find

- (i) Angular velocity of connecting rod and
- (ii) Velocity of slider.

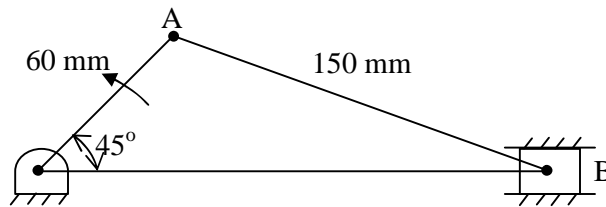

**Configuration diagram**

Step 1: Determine the magnitude and velocity of point A with respect to O,

$$V_A = \omega_{O_1A} \times O_2A = \frac{2\pi \times 300}{60} \times 60$$

$$= 600 \pi \text{ mm/sec}$$

Step 2: Choose a suitable scale to draw velocity vector diagram.

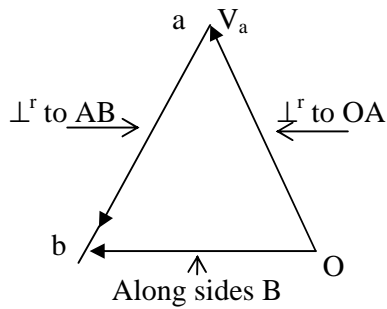

**Velocity vector diagram**

$$V_{ab} = \overline{ab} = 1300 \text{ mm/sec}$$

$$\omega_{ba} = \frac{V_{ba}}{BA} = \frac{1300}{150} = 8.66 \text{ rad/sec}$$

$$V_b = \overline{ob} \text{ velocity of slider}$$

Note: Velocity of slider is along the line of sliding.

3. *Shaper Mechanism:*

In a crank and slotted lever mechanisms crank  $O_2A$  rotates at  $\omega$  rad/sec in CCW direction. Determine the velocity of slider.

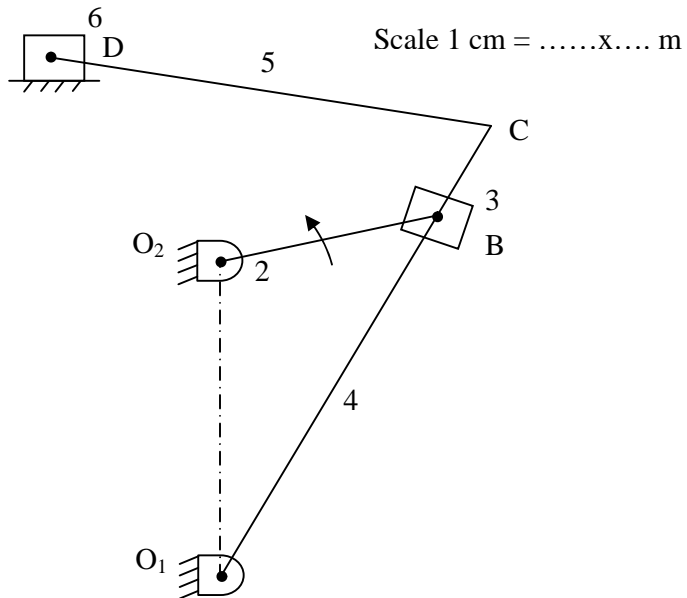

**Configuration diagram**

Scale 1 cm = .....x.... m/s

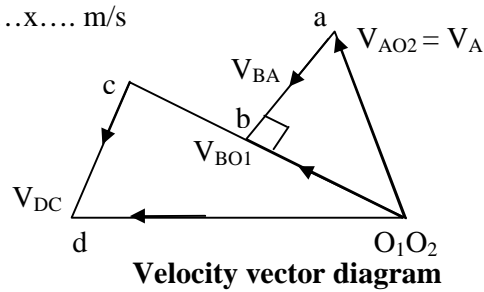

$$V_a = \omega_2 \times O_2A$$

$$\frac{\overrightarrow{O_1b}}{O_1B} = \frac{\overrightarrow{O_1c}}{O_1C}$$

To locate point C

$$\therefore \overrightarrow{O_1c} = \overrightarrow{O_1b} \left( \frac{O_1C}{O_1B} \right)$$

### To Determine Velocity of Rubbing

Two links of a mechanism having turning point will be connected by pins. When the links are motion they rub against pin surface. The velocity of rubbing of pins depends on the angular velocity of links relative to each other as well as direction.

For example: In a four bar mechanism we have pins at points A, B, C and D.

$$\therefore V_{ra} = \omega_{ab} \times \text{radius of pin A } (r_{pa})$$

+ sign is used  $\because$   $\omega_{ab}$  is CW and  $\omega_{bc}$  is CCW i.e. when angular velocities are in opposite directions use + sign when angular velocities are in same directions use -ve sign.

$$V_{rb} = (\omega_{ab} + \omega_{bc}) \text{ radius } r_{pb}$$

$$V_{rc} = (\omega_{bc} + \omega_{cd}) \text{ radius } r_{pc}$$

$$V_{rd} = \omega_{cd} \text{ radius } r_{pd}$$

## Problems on velocity by velocity vector method (Graphical solutions)

### Problem 1:

In a four bar mechanism, the dimensions of the links are as given below:

AB = 50 mm,

BC = 66 mm

CD = 56 mm

and

AD = 100 mm

At a given instant when  $\angle DAB = 60^\circ$  the angular velocity of link AB is 10.5 rad/sec in CCW direction.

Determine,

- Velocity of point C
- Velocity of point E on link BC when BE = 40 mm
- The angular velocity of link BC and CD
- The velocity of an offset point F on link BC, if BF = 45 mm, CF = 30 mm and BCF is read clockwise.
- The velocity of an offset point G on link CD, if CG = 24 mm, DG = 44 mm and DCG is read clockwise.
- The velocity of rubbing of pins A, B, C and D. The ratio of the pins are 30 mm, 40 mm, 25 mm and 35 mm respectively.

### Solution:

Step -1: Construct the configuration diagram selecting a suitable scale.

Scale: 1 cm = 20 mm

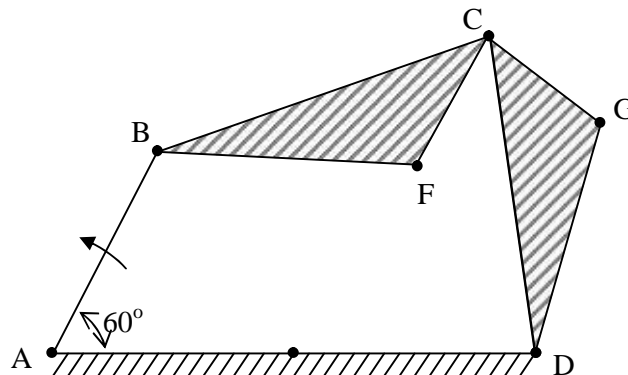

Step - 2: Given the angular velocity of link AB and its direction of rotation determine velocity of point with respect to A (A is fixed hence, it is zero velocity point).

$$\begin{aligned}V_{ba} &= \omega_{BA} \times BA \\ &= 10.5 \times 0.05 = 0.525 \text{ m/s}\end{aligned}$$

Step – 3: To draw velocity vector diagram choose a suitable scale, say 1 cm = 0.2 m/s.

- First locate zero velocity points.
- Draw a line  $\perp^r$  to link AB in the direction of rotation of link AB (CCW) equal to 0.525 m/s.

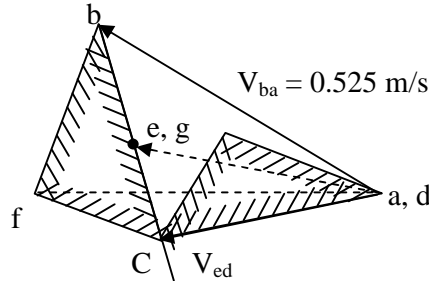

- From b draw a line  $\perp^r$  to BC and from d. Draw d line  $\perp^r$  to CD to interest at C.
- $V_{cb}$  is given vector bc  $V_{bc} = 0.44$  m/s
- $V_{cd}$  is given vector dc  $V_{cd} = 0.39$  m/s

Step – 4: To determine velocity of point E (Absolute velocity) on link BC, first locate the position of point E on velocity vector diagram. This can be done by taking corresponding ratios of lengths of links to vector distance i.e.

$$\frac{be}{bc} = \frac{BE}{BC}$$

$$\therefore be = \frac{BE}{BC} \times V_{cb} = \frac{0.04}{0.066} \times 0.44 = 0.24 \text{ m/s}$$

Join e on velocity vector diagram to zero velocity points a, d / vector  $\overline{de} = V_e = 0.415$  m/s.

Step 5: To determine angular velocity of links BC and CD, we know  $V_{bc}$  and  $V_{cd}$ .

$$\therefore V_{bc} = \omega_{BC} \times BC$$

$$\therefore \omega_{BC} = \frac{V_{bc}}{BC} = \frac{0.44}{0.066} = 6.6 \text{ r/s} \cdot (cw)$$

Similarly,  $V_{cd} = \omega_{CD} \times CD$

$$\therefore \omega_{CD} = \frac{V_{cd}}{CD} = \frac{0.39}{0.056} = 6.96 \text{ r/s} \text{ (CCW)}$$

Step – 6: To determine velocity of an offset point F

- Draw a line  $\perp^r$  to CF from C on velocity vector diagram.

- Draw a line  $\perp^r$  to BF from b on velocity vector diagram to intersect the previously drawn line at 'f'.
- From the point f to zero velocity point a, d and measure vector fa to get  $V_f = 0.495 \text{ m/s}$ .

Step – 7: To determine velocity of an offset point.

- Draw a line  $\perp^r$  to GC from C on velocity vector diagram.
- Draw a line  $\perp^r$  to DG from d on velocity vector diagram to intersect previously drawn line at g.
- Measure vector dg to get velocity of point G.

$$V_g = \overrightarrow{dg} = 0.305 \text{ m/s}$$

Step – 8: To determine rubbing velocity at pins

- Rubbing velocity at pin A will be

$$V_{pa} = \omega_{ab} \times r \text{ of pin A}$$

$$V_{pa} = 10.5 \times 0.03 = 0.315 \text{ m/s}$$

- Rubbing velocity at pin B will be

$$V_{pb} = (\omega_{ab} + \omega_{cb}) \times r_{pb} \text{ of point at B.}$$

$$[\omega_{ab} \text{ CCW and } \omega_{cb} \text{ CW}]$$

$$V_{pb} = (10.5 + 6.6) \times 0.04 = 0.684 \text{ m/s.}$$

- Rubbing velocity at point C will be

$$= 6.96 \times 0.035 = 0.244 \text{ m/s}$$

***Problem 2:***

In a slider crank mechanism the crank is 200 mm long and rotates at 40 rad/sec in a CCW direction. The length of the connecting rod is 800 mm. When the crank turns through  $60^\circ$  from Inner-dead centre.

Determine,

- The velocity of the slider
- Velocity of point E located at a distance of 200 mm on the connecting rod extended.
- The position and velocity of point F on the connecting rod having the least absolute velocity.
- The angular velocity of connecting rod.

- v) The velocity of rubbing of pins of crank shaft, crank and cross head having pins diameters 80,60 and 100 mm respectively.

**Solution:**

Step 1: Draw the configuration diagram by selecting a suitable scale.

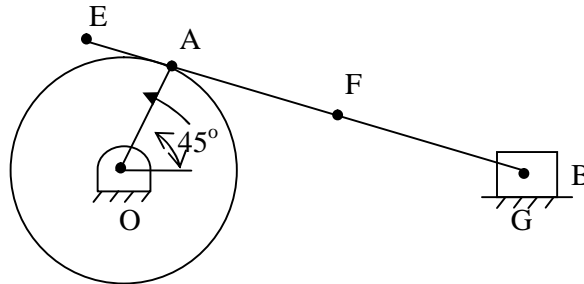

$$V_a = W_{oa} \times OA$$

$$V_a = 40 \times 0.2$$

$$V_a = 8 \text{ m/s}$$

Step 2: Choose a suitable scale for velocity vector diagram and draw the velocity vector diagram.

- Mark zero velocity point o, g.
- Draw  $\vec{oa} \perp^r$  to link OA equal to 8 m/s

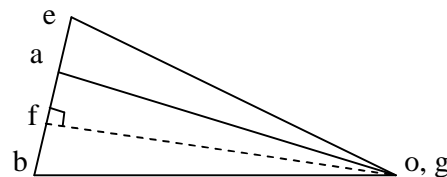

Scale: 1 cm = 2 m/s

- From a draw a line  $\perp^r$  to AB and from o, g draw a horizontal line (representing the line of motion of slider B) to intersect the previously drawn line at b.
- $\vec{ab}$  give  $V_{ba}=4.8 \text{ m/sec}$

Step - 3: To mark point 'e' since 'E' is on the extension of link AB drawn  $\vec{be} = \frac{BE}{AB} \times \vec{ab}$  mark the point e on extension of vector ba. Join e to o, g.  $\vec{ge}$  will give velocity of point E.

$$V_e = \vec{ge} = 8.4 \text{ m/sec}$$

Step 4: To mark point F on link AB such that this has least velocity (absolute).

Draw a line  $\perp^r$  to  $\vec{ab}$  passing through o, g to cut the vector ab at f. From f to o, g.  $\vec{gf}$  will have the least absolute velocity.

- To mark the position of F on link AB.

Find BF by using the relation.

$$\frac{\vec{fb}}{BF} = \frac{\vec{ab}}{AB}$$

$$BF = \frac{\vec{fb}}{\vec{ab}} \times AB = 200\text{mm}$$

Step – 5: To determine the angular velocity of connecting rod.

We know that  $V_{ab} = \omega_{ab} \times AB$

$$\therefore \omega_{ab} = \frac{V_{ab}}{AB} = \mathbf{6 \text{ rad/sec}}$$

Step – 6: To determine velocity of rubbing of pins.

- $V_{\text{crankshaft}} = \omega_{ao} \times \text{radius of crankshaft pin}$   
 $= 8 \times 0.08$   
 $= 0.64 \text{ m/s}$
- $V_{\text{crank pin}} = (\omega_{ab} + \omega_{oa}) r_{\text{crank pin}} = (6 + 8)0.06 = 0.84 \text{ m/sec}$
- $V_{\text{P cross head}} = \omega_{ab} \times r_{\text{cross head}} = 6 \times 0.1 = 0.6 \text{ m/sec}$

- **Problem 3:** A quick return mechanism of crank and slotted lever type shaping machine is shown in Fig. the dimensions of various links are as follows.

$$O_1O_2 = 800 \text{ mm}, O_1B = 300 \text{ mm}, O_2D = 1300 \text{ mm and } DR = 400 \text{ mm}$$

The crank  $O_1B$  makes an angle of  $45^\circ$  with the vertical and rotates at 40 rpm in the CCW direction. Find:

- Velocity of the Ram R, velocity of cutting tool, and
- Angular velocity of link  $O_2D$ .

- **Solution:**

Step 1: Draw the configuration diagram.

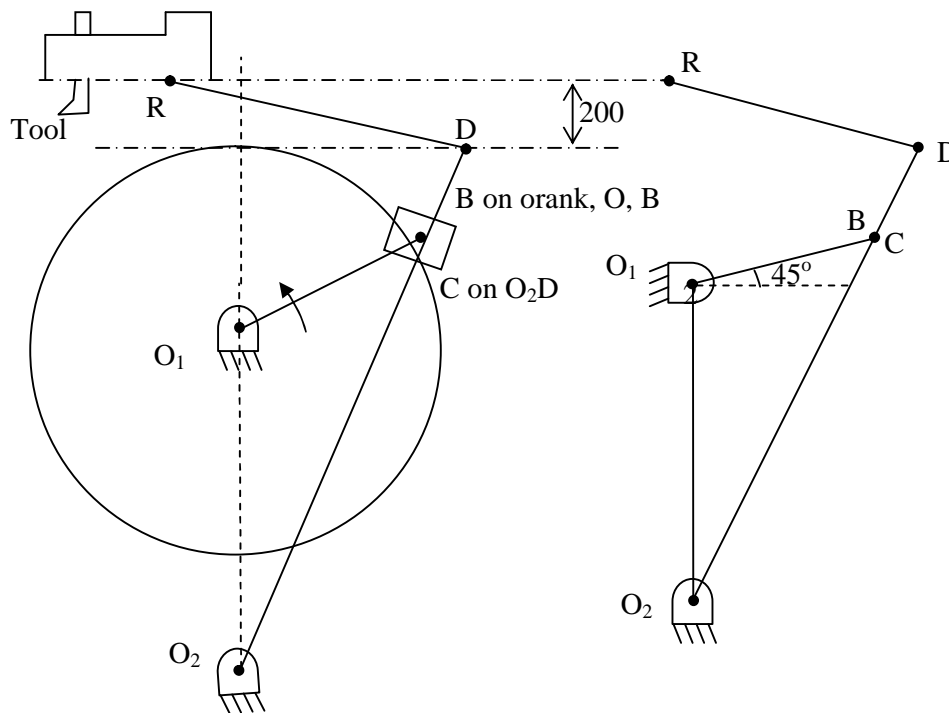

Step 2: Determine velocity of point B.

$$V_b = \omega_{O_1B} \times O_1B$$

$$\omega_{O_1B} = \frac{2\pi N_{O_1B}}{60} = \frac{2\pi \times 40}{60} = 4.18 \text{ rad/sec}$$

$$V_b = 4.18 \times 0.3 = 1.254 \text{ m/sec}$$

Step 3: Draw velocity vector diagram.

Choose a suitable scale 1 cm = 0.3 m/sec

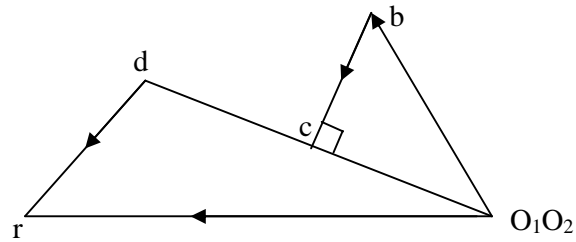

- Draw  $O_1b \perp^r$  to link  $O_1B$  equal to 1.254 m/s.
- From b draw a line along the line of  $O_2B$  and from  $O_1O_2$  draw a line  $\perp^r$  to  $O_2B$ . This intersects at c  $\overrightarrow{bc}$  will measure velocity of sliding of slider and  $\overrightarrow{O_2c}$  will measure the velocity of C on link  $O_2C$ .
- Since point D is on the extension of link  $O_2C$  measure  $\overrightarrow{O_2d}$  such that

$$\overrightarrow{O_2d} = \overrightarrow{O_2c} \frac{O_2D}{O_2C}. \quad \overrightarrow{O_2d} \text{ will give velocity of point D.}$$

- From d draw a line  $\perp^r$  to link DR and from  $O_1O_2$ . Draw a line along the line of stroke of Ram R (horizontal), These two lines will intersect at point r  $\overrightarrow{O_2r}$  will give the velocity of Ram R.
- To determine the angular velocity of link  $O_2D$  determine  $V_d = \overrightarrow{O_2d}$ .

We know that  $V_d = \omega_{O_2D} \times O_2D$ .

$$\therefore \omega_{O_2d} = \frac{\overrightarrow{O_2d}}{O_2D} \text{ r/s}$$

- **Problem 4:** Figure below shows a toggle mechanisms in which the crank OA rotates at 120 rpm. Find the velocity and acceleration of the slider D.

- **Solution:**

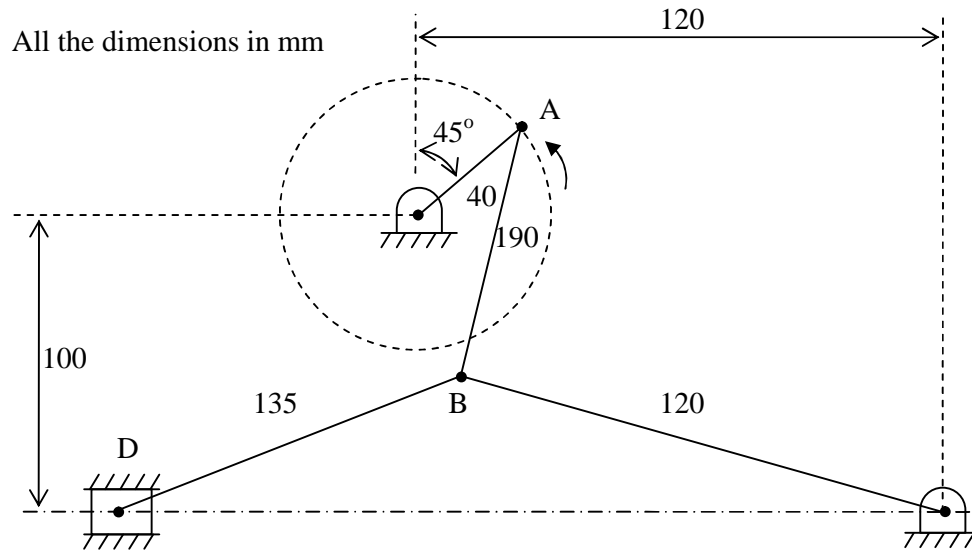

**Configuration Diagram**

Step 1: Draw the configuration diagram choosing a suitable scale.

Step 2: Determine velocity of point A with respect to O.

$$V_{ao} = \omega_{OA} \times OA$$

$$V_{ao} = \frac{2\pi \times 120}{60} \times 0.04 = 5.024 \text{ m/s}$$

Step 3: Draw the velocity vector diagram.

- Choose a suitable scale
- Mark zero velocity points O,q
- Draw vector  $\vec{oa} \perp^r$  to link OA and magnitude = 5.024 m/s.

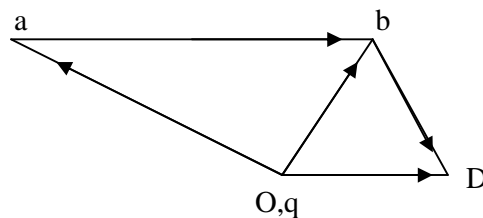

**Velocity vector diagram**

- From a draw a line  $\perp^r$  to AB and from q draw a line  $\perp^r$  to QB to intersect at b.

$$\overline{ab} = V_{ba} \text{ and } \overline{qb} = V_{bq}.$$

- Draw a line  $\perp^r$  to BD from b from q draw a line along the slide to intersect at d.

$$\overline{dq} = V_d \text{ (slider velocity)}$$

- **Problem 5:** A whitworth quick return mechanism shown in figure has the following dimensions of the links.

The crank rotates at an angular velocity of 2.5 r/s at the moment when crank makes an angle of  $45^\circ$  with vertical. Calculate

- the velocity of the Ram S
- the velocity of slider P on the slotted level
- the angular velocity of the link RS.

OP (crank) = 240 mm  
 OA = 150 mm  
 AR = 165 mm  
 RS = 430 mm

- **Solution:**

Step 1: To draw configuration diagram to a suitable scale.

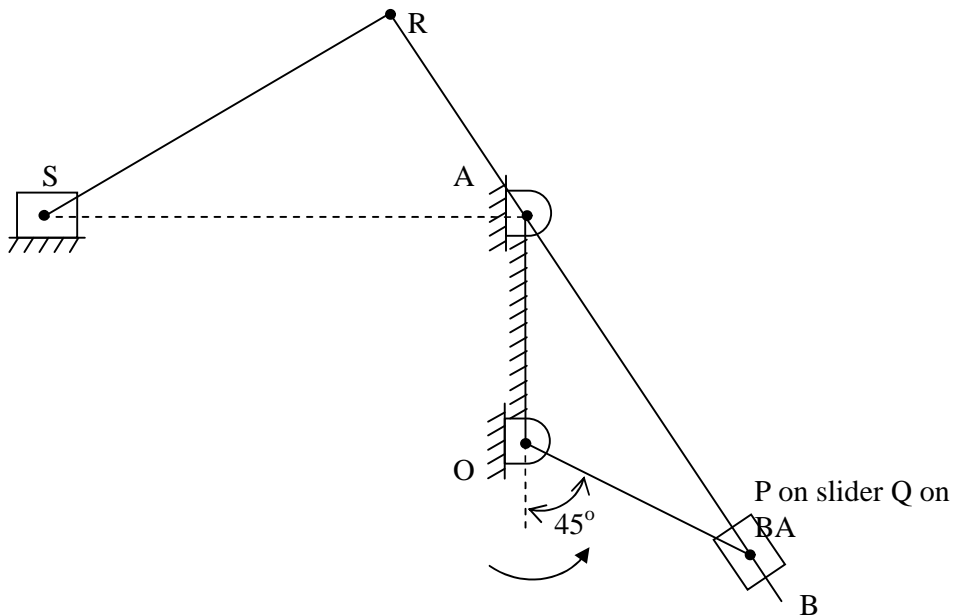

**Configuration Diagram**

Step 2: To determine the absolute velocity of point P.

$$V_P = \omega_{OP} \times OP$$

$$V_{ao} = \frac{2\pi \times 240}{60} \times 0.24 = 0.6 \text{ m/s}$$

Step 3: Draw the velocity vector diagram by choosing a suitable scale.

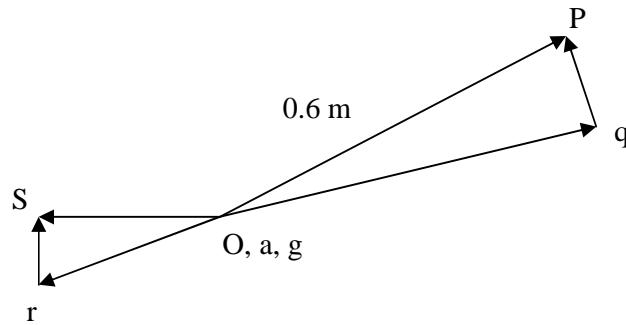

**Velocity vector diagram**

- Draw  $\vec{op} \perp$  link  $OP = 0.6 \text{ m}$ .
- From  $O, a, g$  draw a line  $\perp$  to  $AP/AQ$  and from  $P$  draw a line along  $AP$  to intersect previously draw, line at  $q$ .  $\vec{Pq}$  = Velocity of sliding.

$\vec{aq}$  = Velocity of  $Q$  with respect to  $A$ .

$$V_{qa} = \vec{aq} =$$

- Angular velocity of link  $RS = \omega_{RS} = \frac{\vec{sr}}{SR} \text{ rad/sec}$

- Problem 6:** A toggle mechanism is shown in figure along with the diagrams of the links in mm. find the velocities of the points B and C and the angular velocities of links AB, BQ and BC. The crank rotates at 50 rpm in the clockwise direction.

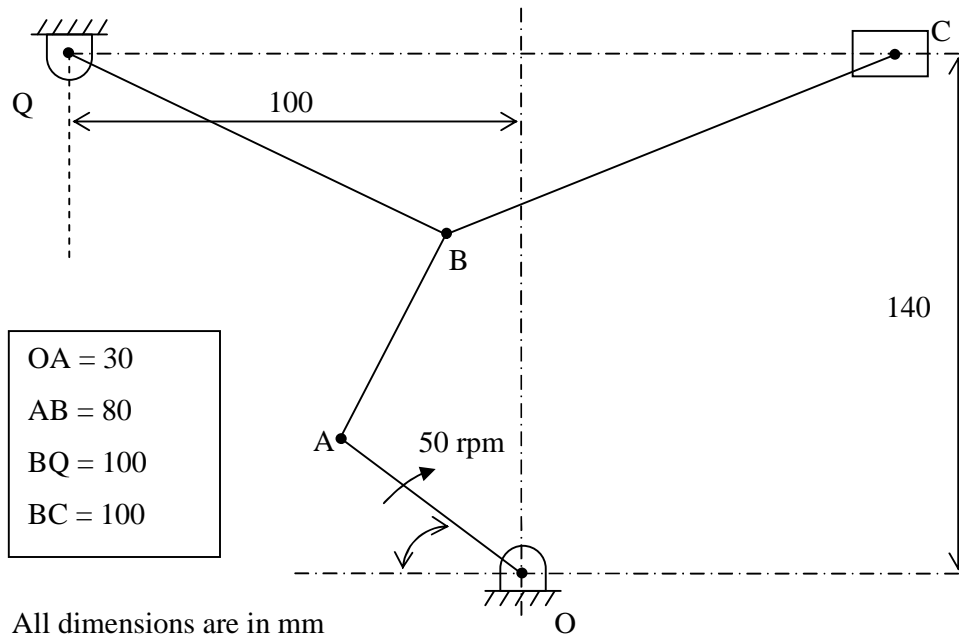

- Solution**

Step 1: Draw the configuration diagram to a suitable scale.

Step 2: Calculate the magnitude of velocity of A with respect to O.

$$V_a = \omega_{OA} \times OA$$

$$V_a = \left( \frac{2\pi \times 50}{60} \right) \times 0.03 = 0.05\pi \text{ m/s} = 0.1507 \text{ m/s}$$

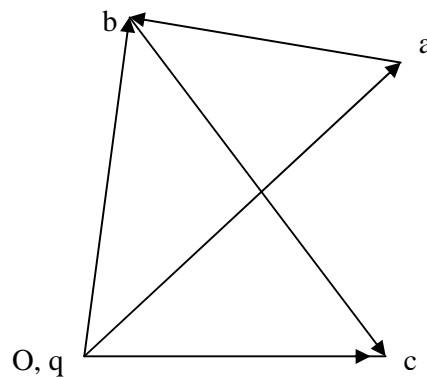

**Vector velocity diagram**

Step 3: Draw the velocity vector diagram by choosing a suitable scale.

- Draw  $\vec{Oa} \perp^r$  to link OA = 0.15 m/s
- From a draw a link  $\perp^r$  to AB and from O, q draw a link  $\perp^r$  to BQ to intersect at b.

$$\vec{ab} = V_{ba} = \quad \text{and} \quad \vec{qb} = V_b = 0.13 \text{ m/s}$$

$$\omega_{ab} = \frac{\vec{ab}}{AB} = 0.74 \text{ r/s (ccw)} \quad \omega_{bq} = \frac{\vec{qb}}{aB} = 1.3 \text{ r/s (ccw)}$$

- From b draw a line  $\perp^r$  to Be and from O, q these two lines intersect at C.

$$\vec{OC} = V_C = 0.106 \text{ m/s}$$

$$\vec{bC} = V_{Cb} =$$

$$\omega_{BC} = \frac{\vec{bc}}{BC} = 1.33 \text{ r/s (ccw)}$$

- **Problem 7:** The mechanism of a stone crusher has the dimensions as shown in figure in mm. If crank rotates at 120 rpm CW. Find the velocity of point K when crank OA is inclined at  $30^\circ$  to the horizontal. What will be the torque required at the crank to overcome a horizontal force of 40 kN at K.

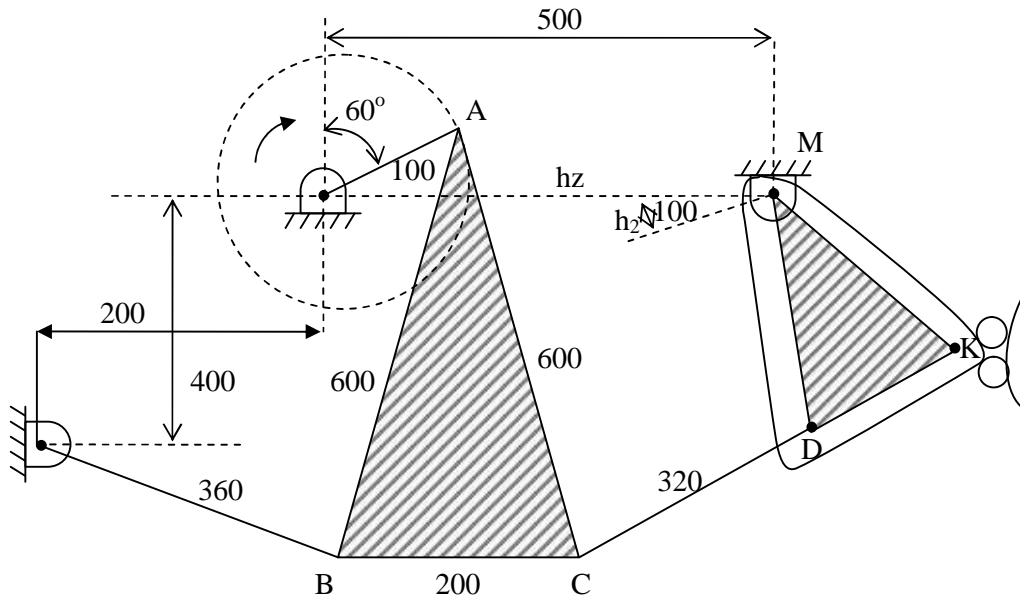

**Configuration diagram**

- **Solution:**

Step 1: Draw the configuration diagram to a suitable scale.

Step 2: Given speed of crank OA determine velocity of A with respect to 'o'.

$$V_a = \omega_{OA} \times OA = \left( \frac{2\pi \times 120}{60} \right) \times 0.1 = 1.26 \text{ m/s}$$

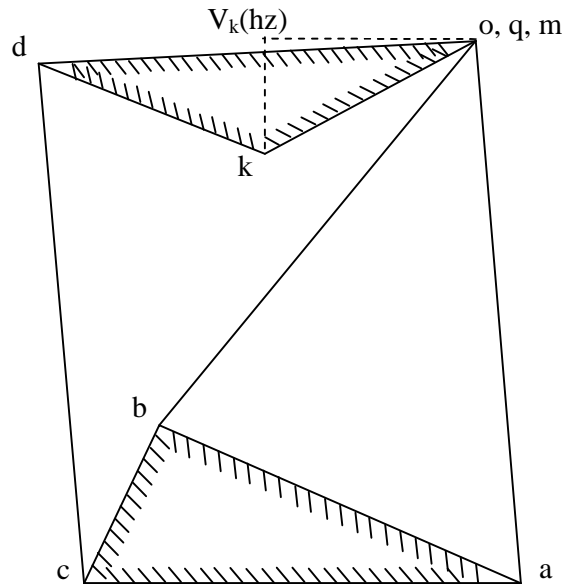

**Velocity vector diagram**

Step 3: Draw the velocity vector diagram by selecting a suitable scale.

- Draw  $\overline{Oa} \perp^r$  to link OA = 1.26 m/s
- From a draw a link  $\perp^r$  to AB and from q draw a link  $\perp^r$  to BQ to intersect at b.
- From b draw a line  $\perp^r$  to BC and from a, draw a line  $\perp^r$  to AC to intersect at c.
- From c draw a line  $\perp^r$  to CD and from m draw a line  $\perp^r$  to MD to intersect at d.
- From d draw a line  $\perp^r$  to KD and from m draw a line  $\perp^r$  to KM to x intersect the previously drawn line at k.
- Since we have to determine the torque required at OA to overcome a horizontal force of 40 kN at K. Draw a the horizontal line from o, q, m and c line  $\perp^r$  to this line from k.

$$\therefore (\omega T)_{\perp^r P} = (\omega T)_{\perp^r O}$$

$$V = \omega R \quad T = F \times P \quad F = \frac{T}{r}$$

$$\therefore \omega_{OA} T_{OA} = F_k V_k \text{ horizontal}$$

$$\therefore T_{OA} = \frac{F_k V_{k(hz)}}{\omega_{OA}}$$

$$T_{OA} = \frac{40000 \times 0.45}{12.6} = \text{N-m}$$

- **Problem 8:** In the mechanism shown in figure link  $OA = 320$  mm,  $AC = 680$  mm and  $OQ = 650$  mm.

Determine,

- The angular velocity of the cylinder
- The sliding velocity of the plunger
- The absolute velocity of the plunger

When the crank  $OA$  rotates at  $20$  rad/sec clockwise.

• **Solution:**

Step 1: Draw the configuration diagram.

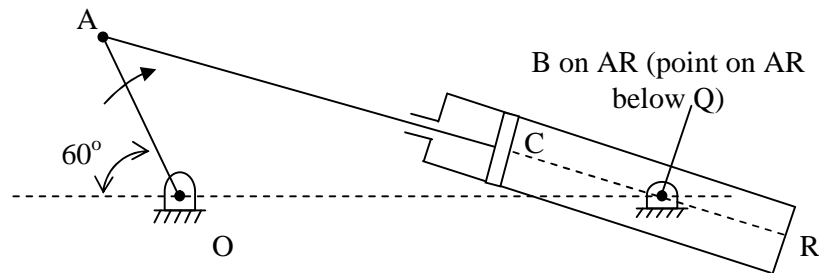

Step 2: Draw the velocity vector diagram

- o Determine velocity of point A with respect to O.

$$V_a = \omega_{OA} \times OA = 20 \times 0.32 = 6.4 \text{ m/s}$$

- o Select a suitable scale to draw the velocity vector diagram.
- o Mark the zero velocity point. Draw vector  $\vec{Oa} \perp^r$  to link  $OA$  equal to  $6.4$  m/s.

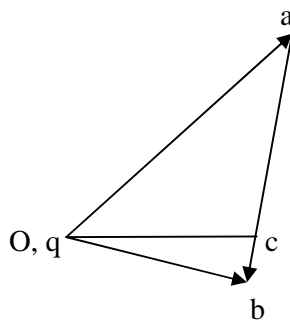

- o From a draw a line  $\perp^r$  to  $AB$  and from o, q, draw a line perpendicular to  $AB$ .
- o To mark point c on  $\vec{ab}$

We know that  $\frac{\vec{ab}}{\vec{ac}} = \frac{AB}{AC}$



Step 2: Determine the velocity of point B with respect to A.

$$V_b = \omega_{BA} \times BA$$

$$V_b = \frac{2\pi \times 300}{60} \times 0.1 = 3.14 \text{ m/s}$$

Step 3: Draw the velocity vector diagram choosing a suitable scale.

- Mark zero velocity point a, d, o, g.

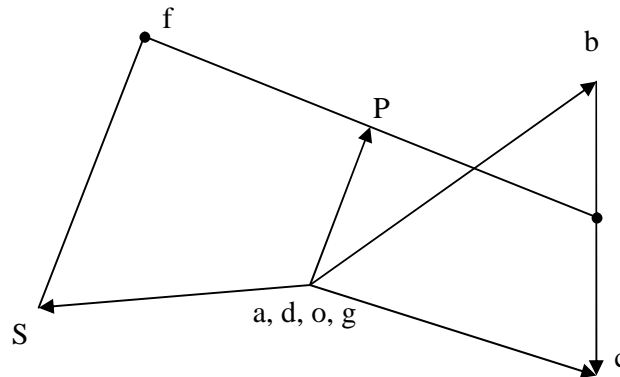

**Velocity vector diagram**

- From 'a' draw a line  $\perp^r$  to AB and equal to 3.14 m/s.
- From 'b' draw a line  $\perp^r$  to DC to intersect at C.
- Mark a point 'e' on vector bc such that
 
$$\vec{be} = \vec{bc} \times \frac{BE}{BC}$$
- From 'e' draw a line  $\perp^r$  to PE and from 'a,d' draw a line along PE to intersect at P.
- Extend the vector ep to ef such that  $\vec{ef} = \frac{\vec{ef}}{EP} \times EF$
- From 'f' draw a line  $\perp^r$  to Sf and from zero velocity point draw a line along the slider 'S' to intersect the previously drawn line at S.
- Velocity of slider  $\vec{gS} = 2.6 \text{ m/s}$ . Angular Velocity of link EF.
- Velocity of link F in the swivel block =  $\vec{OP} = 1.85 \text{ m/s}$ .

- **Problem 10:** Figure shows two wheels 2 and 4 which rolls on a fixed link 1. The angular uniform velocity of wheel is 2 is 10 rad/sec. Determine the angular velocity of links 3 and 4, and also the relative velocity of point D with respect to point E.

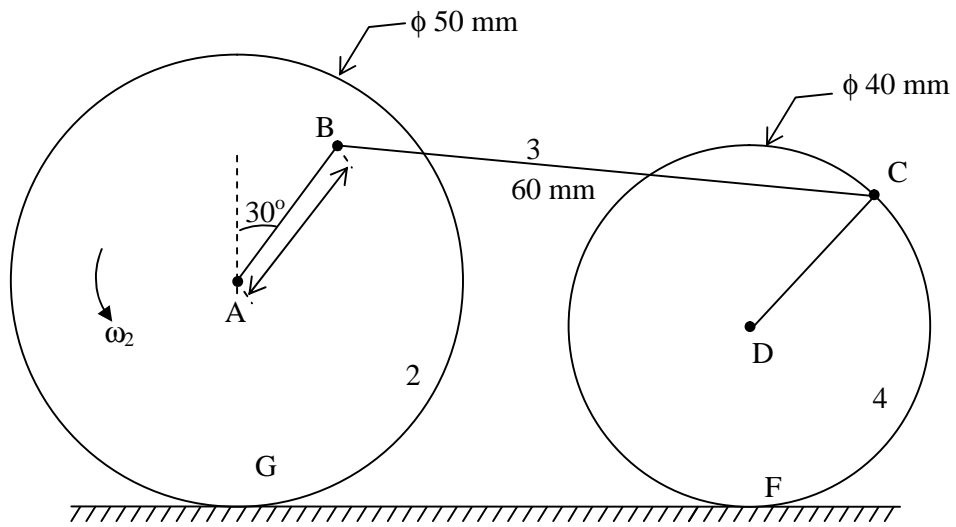

• **Solution:**

Step 1: Draw the configuration diagram.

Step 2: Given  $\omega_2 = 10$  rad/sec. Calculate velocity of B with respect to G.

$$V_b = \omega_2 \times BG$$

$$V_b = 10 \times 43 = 430 \text{ mm/sec.}$$

Step 3: Draw the velocity vector diagram by choosing a suitable scale.

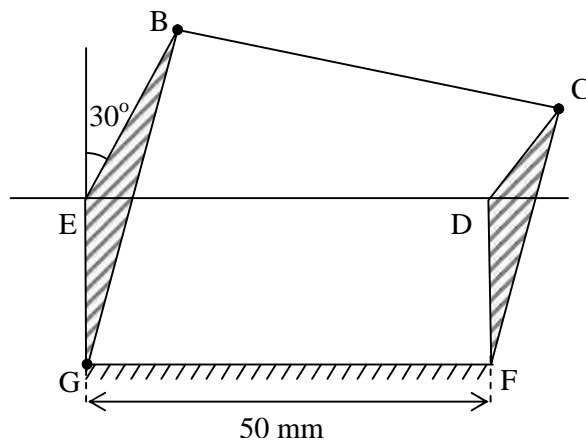

**Redrawn configuration diagram**

- **Velocity vector diagram**

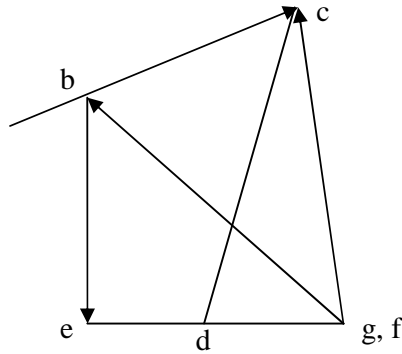

- Draw  $\vec{gb} = 0.43 \text{ m/s} \perp^r \text{ to BG}$ .
- From b draw a line  $\perp^r$  to BC and from 'f' draw a line  $\perp^r$  to CF to intersect at C.
- From b draw a line  $\perp^r$  to BE and from g, f draw a line  $\perp^r$  to GE to intersect at e.
- From c draw a line  $\perp^r$  to CD and from f draw a line  $\perp^r$  to FD to intersect at d.

- **Problem 11:** For the mechanism shown in figure link 2 rotates at constant angular velocity of 1 rad/sec construct the velocity polygon and determine.

- Velocity of point D.
- Angular velocity of link BD.
- Velocity of slider C.

- **Solution:**

Step 1: Draw configuration diagram.

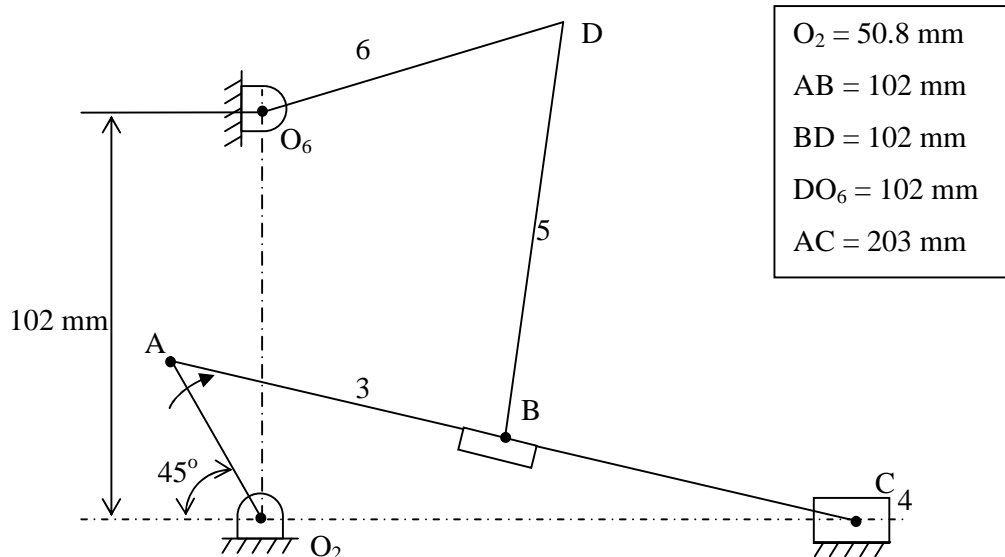

Step 2: Determine velocity of A with respect to  $O_2$ .

$$V_b = \omega_2 \times O_2A$$

$$V_b = 1 \times 50.8 = 50.8 \text{ mm/sec.}$$

Step 3: Draw the velocity vector diagram, locate zero velocity points  $O_2O_6$ .

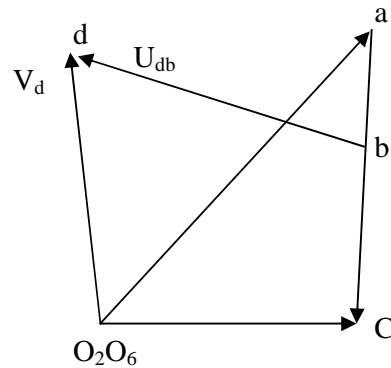

- From  $O_2, O_6$  draw a line  $\perp^r$  to  $O_2A$  in the direction of rotation equal to 50.8 mm/sec.
- From  $a$  draw a line  $\perp^r$  to  $Ac$  and from  $O_2, O_6$  draw a line along the line of stocks of  $c$  to intersect the previously drawn line at  $c$ .
- Mark point  $b$  on vector  $ac$  such that  $\vec{ab} = \frac{\vec{ab}}{AC} \times AB$
- From  $b$  draw a line  $\perp^r$  to  $BD$  and from  $O_2, O_6$  draw a line  $\perp^r$  to  $O_6D$  to intersect at  $d$ .

Step 4:  $V_d = \vec{O_6d} = 32 \text{ mm/sec}$

$$\omega_{bd} = \frac{\vec{bd}}{BD} =$$

$$V_c = \vec{O_2C} =$$

### ADDITIONAL PROBLEMS FOR PRACTICE

- **Problem 1:** In a slider crank mechanism shown in offset by a perpendicular distance of 50 mm from the centre  $C$ .  $AB$  and  $BC$  are 750 mm and 200 mm long respectively crank  $BC$  is rotating  $\omega$  at a uniform speed of 200 rpm. Draw the velocity vector diagram and determine velocity of slider  $A$  and angular velocity of link  $AB$ .

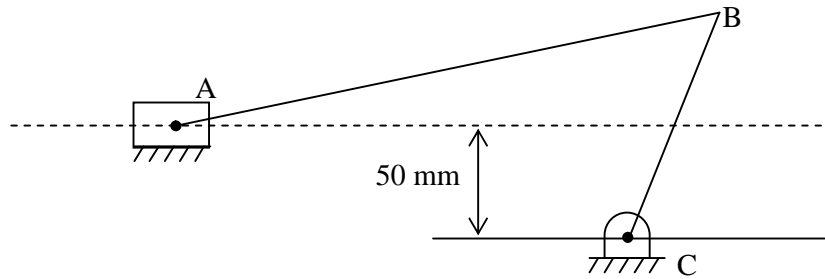

- Problem 2:** For the mechanism shown in figure determine the velocities at points C, E and F and the angular velocities of links, BC, CDE and EF.

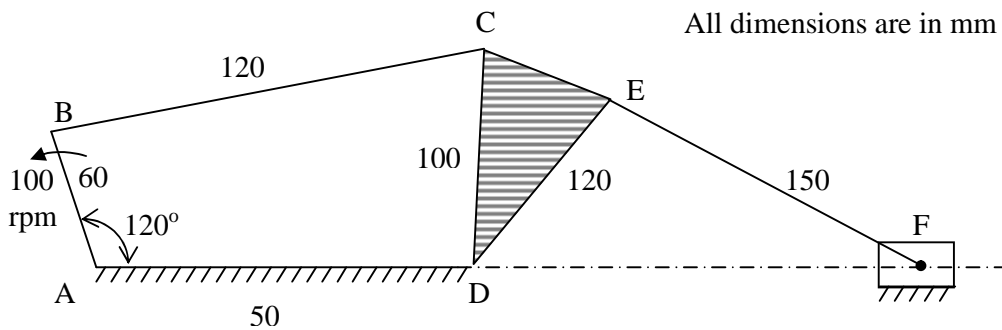

- The crank of a crank and slotted lever mechanism shown in figure rotates at 100 rpm in the CCW direction. Various lengths of the links are  $OP = 90$  mm,  $OA = 300$  mm,  $AR = 480$  mm and  $RS = 330$  mm. The slider moves along an axis perpendicular to  $\perp^l AO$  and in 120 mm from O. Determine the velocity of the slider when  $\angle AOP$  is  $135^\circ$  and also mention the maximum velocity of slider.

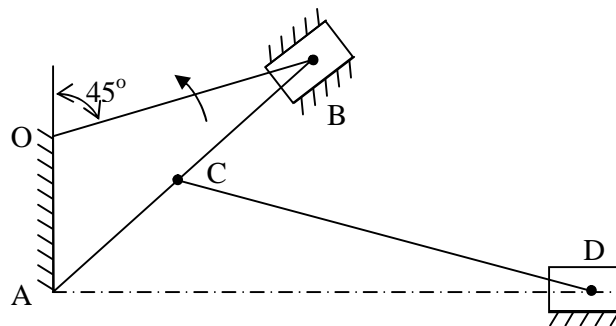

- Problem 4:** Find the velocity of link 4 of the scotch yoke mechanism shown in figure. The angular speed of link 2 is 200 rad/sec CCW, link  $O_2P = 40$  mm.

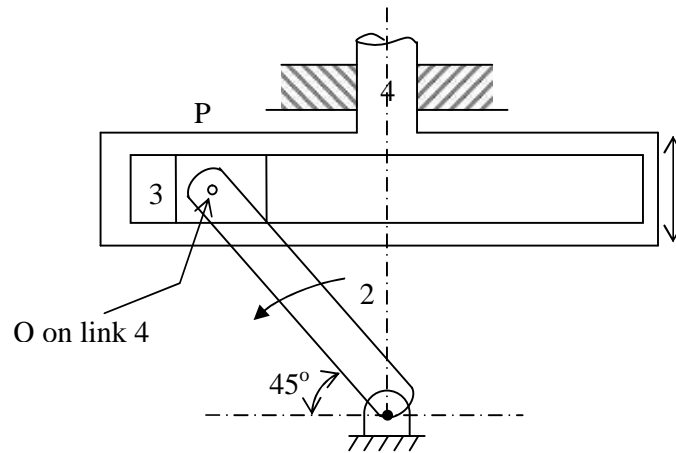

- Problem 5:** In the mechanism shown in figure link AB rotates uniformly in  $C\omega$  direction at 240 rpm. Determine the linear velocity of B and angular velocity of EF.

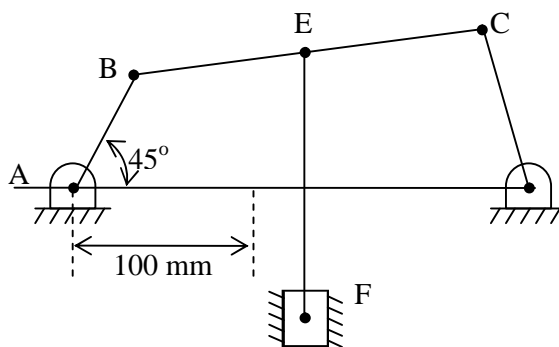

$AB = 160$ mm
$BC = 160$ mm
$CD = 100$ mm
$AD = 200$ mm
$EF = 200$ mm
$CE = 40$ mm

## II Method

- **Instantaneous Method**

To explain instantaneous centre let us consider a plane body P having a non-linear motion relative to another body q consider two points A and B on body P having velocities as  $V_a$  and  $V_b$  respectively in the direction shown.

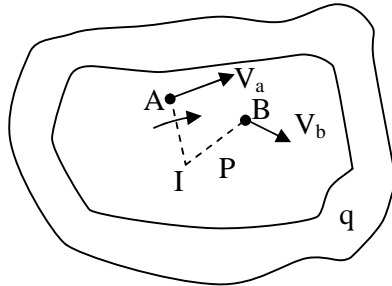

**Fig. 1**

If a line is drawn  $\perp^r$  to  $V_a$ , at A the body can be imagined to rotate about some point on the line. Thirdly, centre of rotation of the body also lies on a line  $\perp^r$  to the direction of  $V_b$  at B. If the intersection of the two lines is at I, the body P will be rotating about I at that instant. The point I is known as the instantaneous centre of rotation for the body P. The position of instantaneous centre changes with the motion of the body.

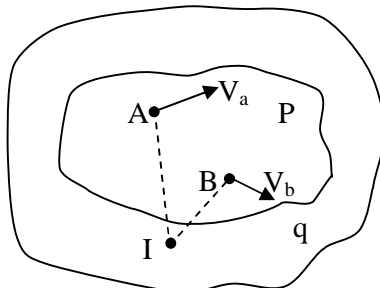

**Fig. 2**

In case of the  $\perp^r$  lines drawn from A and B meet outside the body P as shown in Fig 2.

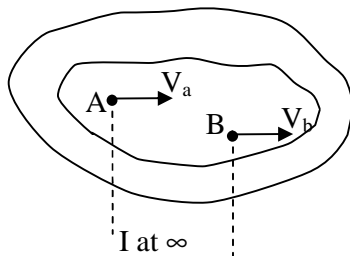

**Fig. 3**

If the direction of  $V_a$  and  $V_b$  are parallel to the  $\perp^r$  at A and B met at  $\infty$ . This is the case when the body has linear motion.

- **Number of Instantaneous Centers**

The number of instantaneous centers in a mechanism depends upon number of links. If  $N$  is the number of instantaneous centers and  $n$  is the number of links.

$$N = \frac{n(n-1)}{2}$$

- **Types of Instantaneous Centers**

There are three types of instantaneous centers namely fixed, permanent and neither fixed nor permanent.

Example: Four bar mechanism.  $n = 4$ .

$$N = \frac{n(n-1)}{2} = \frac{4(4-1)}{2} = 6$$

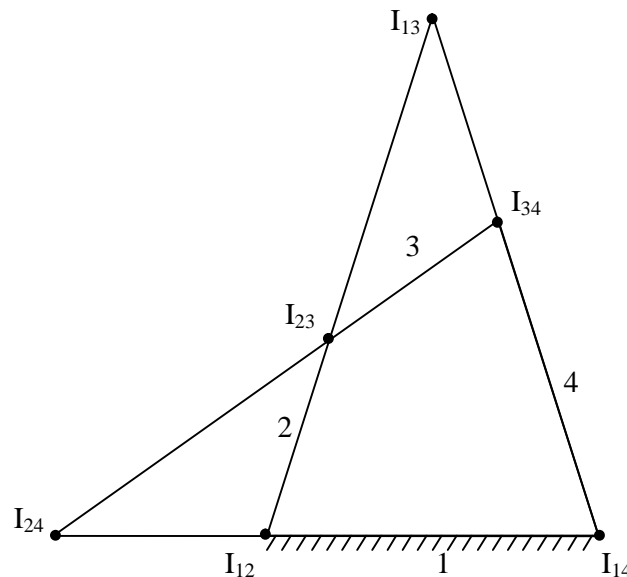

Fixed instantaneous center  $I_{12}, I_{14}$

Permanent instantaneous center  $I_{23}, I_{34}$

Neither fixed nor permanent instantaneous center  $I_{13}, I_{24}$

- **Arnold Kennedy theorem of three centers:**

*Statement:* If three bodies have motion relative to each other, their instantaneous centers should lie in a straight line.

Proof:

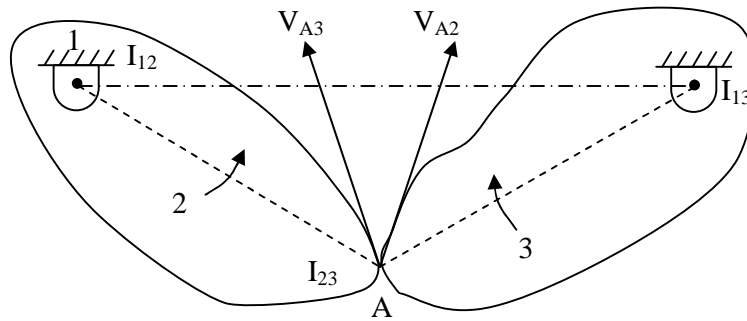

Consider a three link mechanism with link 1 being fixed link 2 rotating about  $I_{12}$  and link 3 rotating about  $I_{13}$ . Hence,  $I_{12}$  and  $I_{13}$  are the instantaneous centers for link 2 and link 3. Let us assume that instantaneous center of link 2 and 3 be at point A i.e.  $I_{23}$ . Point A is a coincident point on link 2 and link 3.

Considering A on link 2, velocity of A with respect to  $I_{12}$  will be a vector  $V_{A2}$   $\perp^r$  to link A  $I_{12}$ . Similarly for point A on link 3, velocity of A with respect to  $I_{13}$  will be  $\perp^r$  to A  $I_{13}$ . It is seen that velocity vector of  $V_{A2}$  and  $V_{A3}$  are in different directions which is impossible. Hence, the instantaneous center of the two links cannot be at the assumed position.

It can be seen that when  $I_{23}$  lies on the line joining  $I_{12}$  and  $I_{13}$  the  $V_{A2}$  and  $V_{A3}$  will be same in magnitude and direction. Hence, for the three links to be in relative motion all the three centers should lie in a same straight line. Hence, the proof.

Steps to locate instantaneous centers:

Step 1: Draw the configuration diagram.

Step 2: Identify the number of instantaneous centers by using the relation

$$N = \frac{(n-1)n}{2}$$

Step 3: Identify the instantaneous centers by circle diagram.

Step 4: Locate all the instantaneous centers by making use of Kennedy's theorem.

To illustrate the procedure let us consider an example.

A slider crank mechanism has lengths of crank and connecting rod equal to 200 mm and 200 mm respectively locate all the instantaneous centers of the mechanism for the position of the crank when it has turned through  $30^\circ$  from IOC. Also find velocity of slider and angular velocity of connecting rod if crank rotates at 40 rad/sec.

Step 1: Draw configuration diagram to a suitable scale.

Step 2: Determine the number of links in the mechanism and find number of instantaneous centers.

$$N = \frac{(n-1)n}{2}$$

$$n = 4 \text{ links} \quad N = \frac{4(4-1)}{2} = 6$$

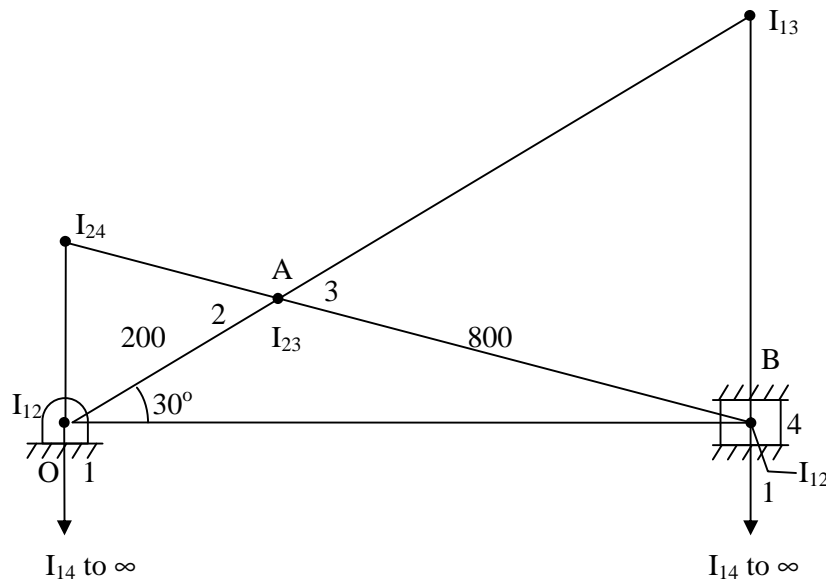

Step 3: Identify instantaneous centers.

- Suit it is a 4-bar link the resulting figure will be a square.

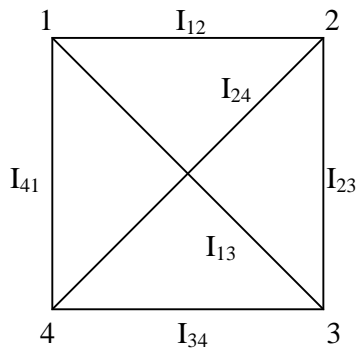

OR

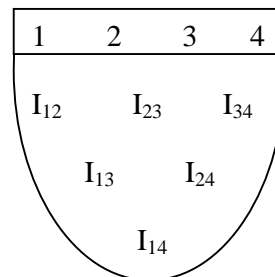

- Locate fixed and permanent instantaneous centers. To locate neither fixed nor permanent instantaneous centers use Kennedy's three centers theorem.

Step 4: Velocity of different points.

$$V_a = \omega_2 AI_{12} = 40 \times 0.2 = 8 \text{ m/s}$$

$$\text{also } V_a = \omega_2 \times AI_{13}$$

$$\therefore \omega_3 = \frac{V_a}{AI_{13}}$$

$$V_b = \omega_3 \times BI_{13} = \text{Velocity of slider.}$$

• **Problem 2:**

A four bar mechanisms has links AB = 300 mm, BC = CD = 360 mm and AD = 600 mm. Angle  $\angle BAD = 60^\circ$ . Crank AB rotates in  $\omega$  direction at a speed of 100 rpm. Locate all the instantaneous centers and determine the angular velocity of link BC.

• **Solution:**

Step 1: Draw the configuration diagram to a suitable scale.

Step 2: Find the number of Instantaneous centers

$$N = \frac{(n-1)n}{2} = \frac{4(4-1)}{2} = 6$$

Step 3: Identify the IC's by circular method or book keeping method.

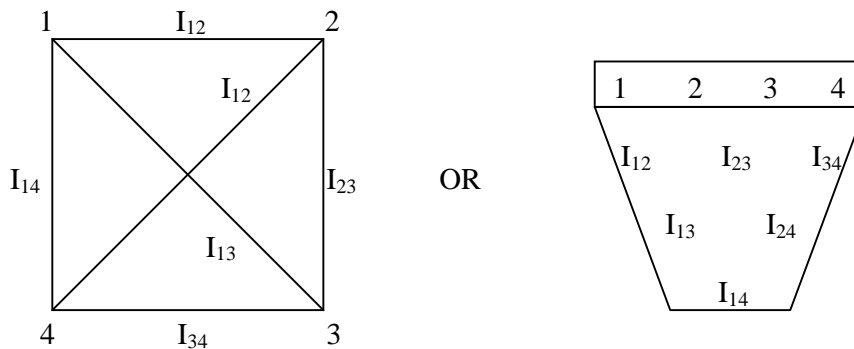

Step 4: Locate all the visible IC's and locate other IC's by Kennedy's theorem.

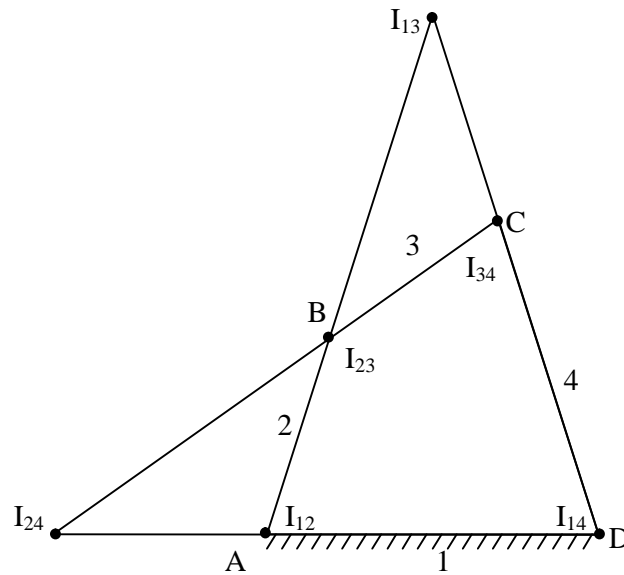

$$V_b = \omega_2 \times BI_{12} = \frac{2\pi \times 100}{60} \times 0.3 = \text{m/sec}$$

Also  $V_b = \omega_3 \times BI_{13}$

$$\omega_3 = \frac{V_b}{BI_{13}} = \text{rad/sec}$$

- For a mechanism in figure crank OA rotates at 100 rpm clockwise using I.C. method determine the linear velocities of points B, C, D and angular velocities of links AB, BC and CD.

$$OA = 20 \text{ cm}$$

$$AB = 150 \text{ cm}$$

$$BC = 60 \text{ cm}$$

$$CD = 50 \text{ cm}$$

$$BE = 40 \text{ cm}$$

$$OE = 135 \text{ cm}$$

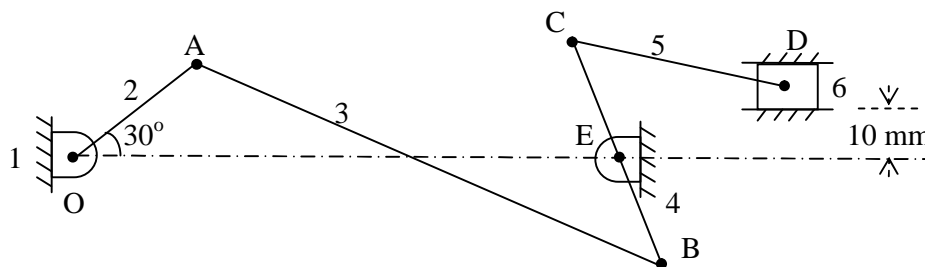

$$V_a = \omega_{OA} \times OA$$

$$V_a = \frac{2\pi \times 100}{60} \times 0.2 = 2.1 \text{ m/s}$$

$$n = 6 \text{ links}$$

$$N = \frac{n(n-1)}{2} = 15$$

1	2	3	4	5	6	5
	12	23	34	45	56	4
		13	24	35	46	3
			14	25	36	2
				15	26	1
					16	---
						15
						---

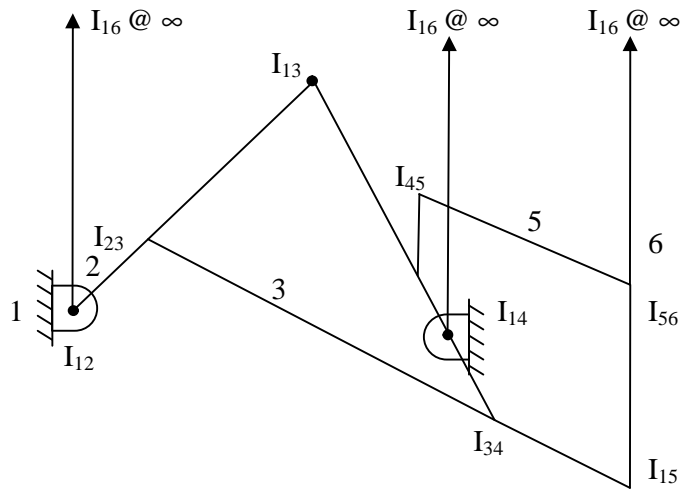

**Link 3**

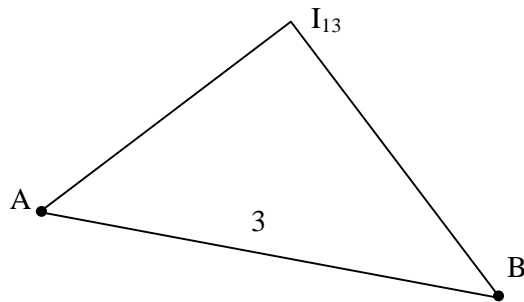

$$V_a = \omega_3 AI_{13}$$

$$\omega_3 = \frac{V_a}{AI_{13}} = 2.5 \text{ rad/sec}$$

$$V_b = \omega_3 \times BI_{13} = 2.675 \text{ m/s}$$

**Link 4**

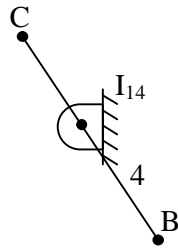

Also  $V_b = \omega_4 \times BI_{14}$

$$\omega_4 = \frac{V_b}{BI_{14}} = 6.37 \text{ rad/sec}$$

$$V_C = \omega_4 \times CI_{14} = 1.273 \text{ m/s}$$

**Link 5**

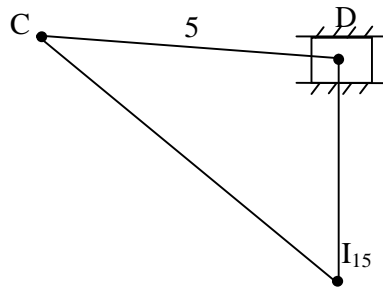

$$V_C = \omega_5 \times CI_{15}$$

$$\omega_5 = \frac{V_C}{AI_{15}} = 1.72 \text{ rad/sec}$$

$$V_d = \omega_5 \times DI_{15} = 0.826 \text{ m/s}$$

<i>Answers</i>
$V_b = 2.675 \text{ m/s}$
$V_C = 1.273 \text{ m/s}$
$V_d = 0.826 \text{ m/s}$
$\omega_{ab} = 2.5 \text{ rad/sec}$
$\omega_{bc} = 6.37 \text{ rad/sec}$
$\omega_{cd} = 1.72 \text{ rad/sec}$

- In the toggle mechanism shown in figure the slider D is constrained to move in a horizontal path the crank OA is rotating in CCW direction at a speed of 180 rpm the dimensions of various links are as follows:

$$OA = 180 \text{ mm}$$

$$CB = 240 \text{ mm}$$

$$AB = 360 \text{ mm}$$

$$BD = 540 \text{ mm}$$

Find,

- Velocity of slider
- Angular velocity of links AB, CB and BD.

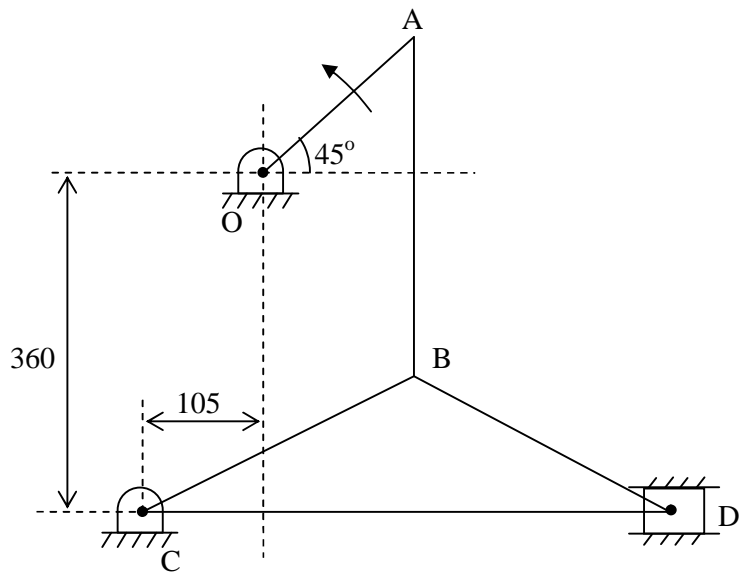

$n = 6$  links

$$N = \frac{n(n-1)}{2} = 15$$

1	2	3	4	5	6		5
	12	23	34	45	56		4
		13	24	35	46		3
			14	25	36		2
				15	26		1
					16		---
							15
							---

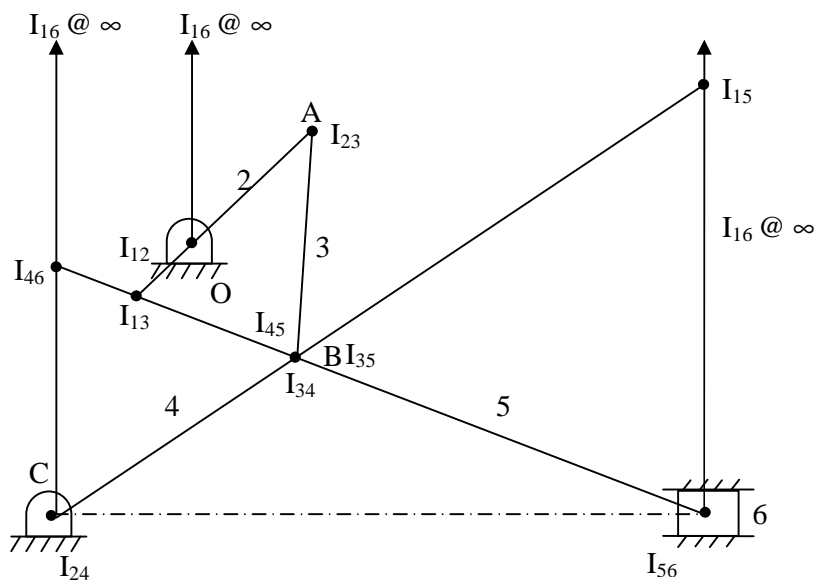

$$V_a = \omega_2 \times AI_{12} = 3.4 \text{ m/s}$$

**Link 3**

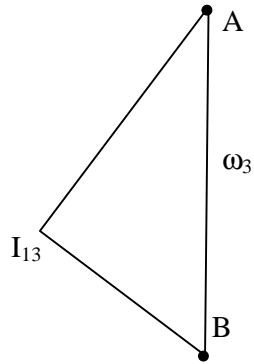

$$V_a = \omega_3 \times AI_{13}$$

$$\omega_3 = \frac{V_a}{AI_{13}} = 2.44 \text{ rad/sec}$$

$$V_b = \omega_3 \times BI_{13}$$

**Link 4**

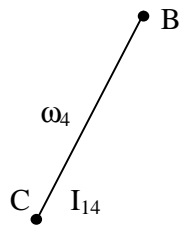

$$V_b = \omega_4 \times BI_{14}$$

$$\omega_4 = \frac{V_b}{BI_{14}} = 11.875 \text{ rad/sec}$$

**Link 5**

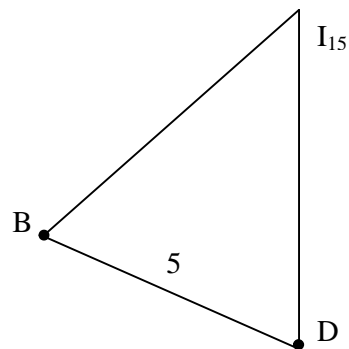

$$V_b = \omega_5 \times BI_{15}$$

$$\omega_5 = \frac{V_b}{BI_{15}} = 4.37 \text{ rad/sec}$$

$$V_d = \omega_5 \times DI_{15} = 2 \text{ m/s}$$

*Answers*  
 $V_d = 2 \text{ m/s}$   
 $\omega_{ab} = 2.44 \text{ rad/sec}$   
 $\omega_{bc} = 11.875 \text{ rad/sec}$   
 $\omega_{cd} = 4.37 \text{ rad/sec}$

- Figure shows a six link mechanism. What will be the velocity of cutting tool D and the angular velocities of links BC and CD if crank rotates at 10 rad/sec.

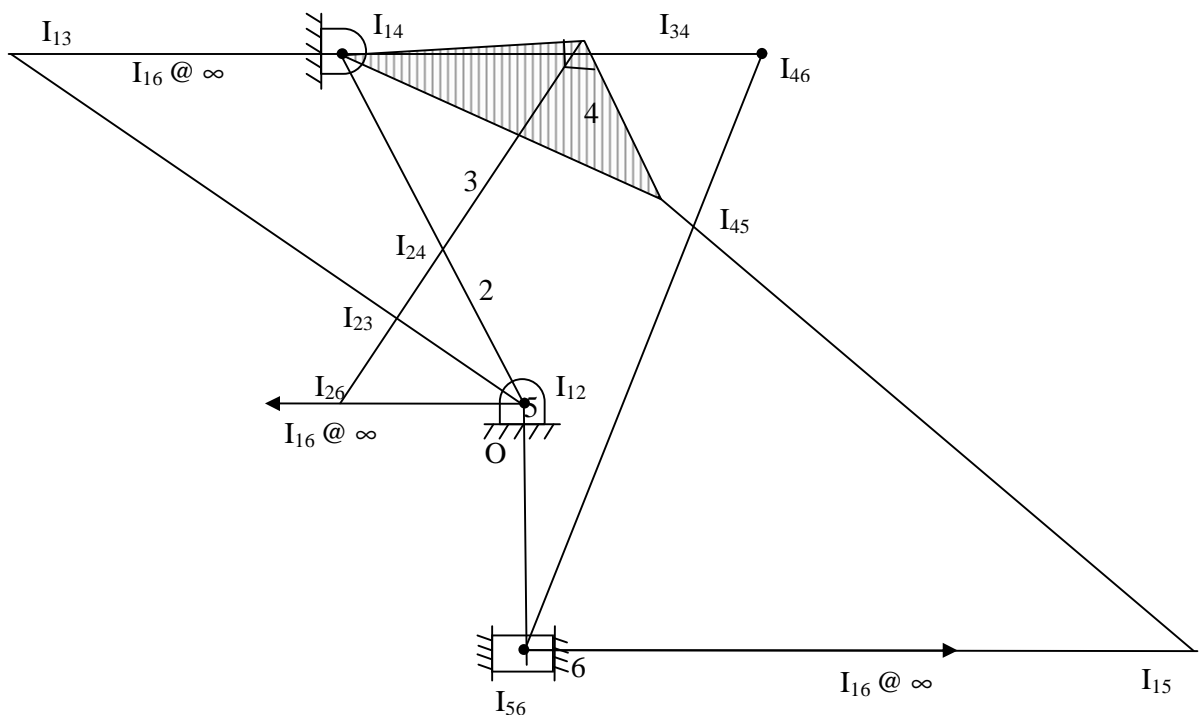
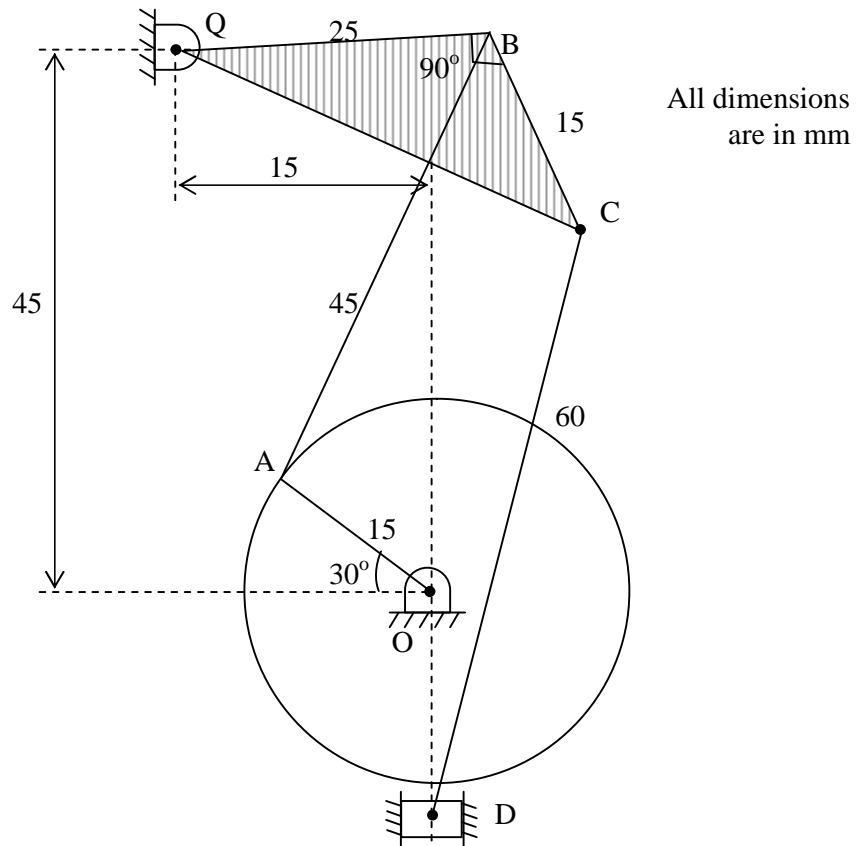

$$V_a = \omega_2 \times AI_{12} = 10 \times 0.015$$

$$V_a = \omega_2 \times AI_{12} = 0.15 \text{ m/s}$$

**Link 3**

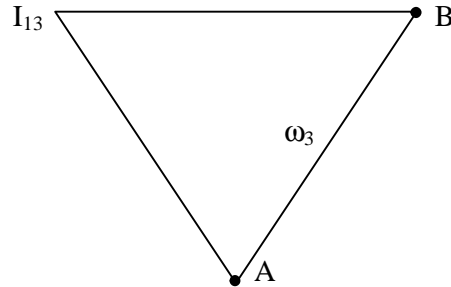

$$V_a = \omega_3 \times AI_{13}$$

$$\omega_3 = \frac{V_a}{AI_{13}}$$

$$V_b = \omega_3 \times BI_{13}$$

**Link 4**

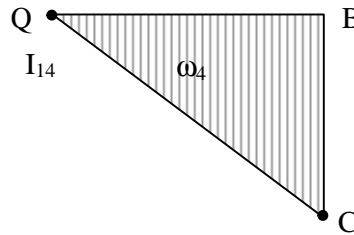

$$V_b = \omega_4 \times BI_{14}$$

$$\omega_4 = \frac{V_b}{BI_{14}} = 4.25 \text{ rad/sec}$$

$$V_C = \omega_4 \times CI_{14}$$

**Link 5**

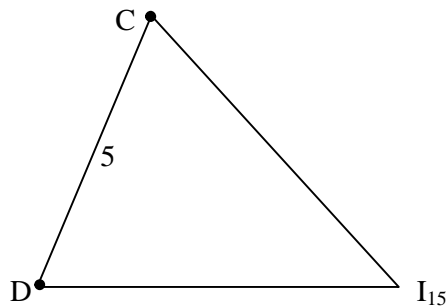

$$V_C = \omega_5 \times CI_{15}$$

$$\omega_5 = \frac{V_C}{AI_{15}} = 1.98 \text{ rad/sec}$$

$$V_d = \omega_5 \times DI_{15} = 1.66 \text{ m/s}$$

*Answers*

$$V_d = 1.66 \text{ m/s}$$

$$\omega_{bc} = 4.25 \text{ rad/sec}$$

$$\omega_{cd} = 1.98 \text{ rad/sec}$$

- A whitworth quick return mechanism shown in figure has a fixed link OA and crank OP having length 200 mm and 350 mm respectively. Other lengths are AR = 200 mm and RS = 40 mm. Find the velocity of the rotation using IC method when crank makes an angle of  $120^\circ$  with fixed link and rotates at 10 rad/sec.

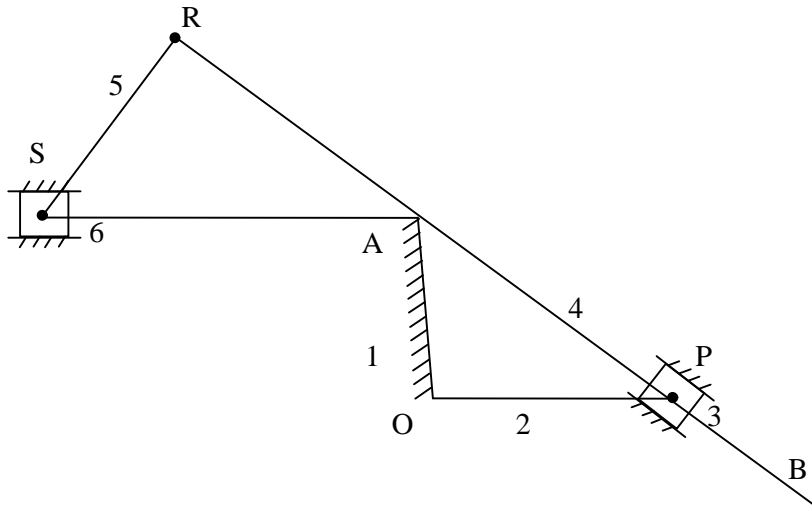

Locate the IC's

$$n = 6 \text{ links}$$

$$N = \frac{n(n-1)}{2} = 15$$

1	2	3	4	5	6	5
	12	23	34	45	56	4
		13	24	35	46	3
			14	25	36	2
				15	26	1
					16	---
						15
						---



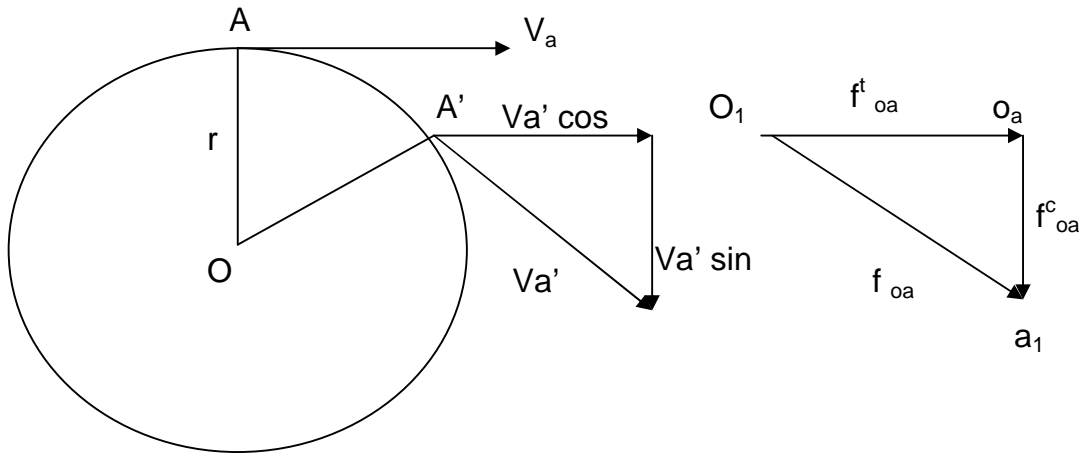

$$V_{a'} = (\omega + \alpha \delta t) r$$

Velocity of A parallel to OA = 0

Velocity of A' parallel to OA =  $V_{a'} \sin \delta \theta$

Therefore change in velocity =  $V_{a'} \sin \delta \theta - 0$

$$\text{Centripetal acceleration} = f^c = \frac{(\omega + \alpha \delta t) r \sin \delta \theta}{\delta t}$$

as  $\delta t$  tends to Zero  $\sin \delta \theta$  tends to

$$\therefore \frac{(\omega r \delta \theta + \alpha r \delta \theta \delta t)}{\delta t}$$

$$f^c = r \left( \frac{d\omega}{dt} \right) = \alpha r$$

$$\text{But } V = \omega r \text{ or } \omega = V/r$$

$$\text{Hence, } f^c = \alpha r = \frac{dV}{dt} = \frac{V^2}{r}$$

## 2. Tangential Acceleration:

$$V_{a'} = (\omega + \alpha \delta t) r$$

Velocity of A perpendicular to OA =  $V_a$

Velocity of A' perpendicular to OA =  $V_{a'} \cos \delta \theta$

Therefore change in velocity =  $V_{a'} \cos \delta \theta - V_a$

$$\text{Tangential acceleration} = f^t = \frac{(\omega + \alpha \delta t) r \cos \delta \theta - \omega r}{\delta t}$$

as  $\delta t$  tends to Zero  $\cos \delta \theta$  tends to 1

$$\therefore \frac{(\omega r + \alpha r \delta t) - \omega r}{\delta t}$$

$$f^t = \alpha r$$

Example:

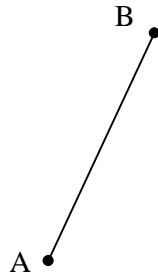

$$f_{ab}^c = \omega^2 AB$$

Acts parallel to BA and acts from B to A.

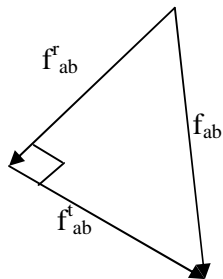

$f^t = \alpha BA$  acts  $\perp^r$  to link.

$$f_{BA} = f_{BA}^r + f_{BA}^t$$

- **Problem 1:** Four bar mechanism. For a 4-bar mechanism shown in figure draw velocity and acceleration diagram.

All dimensions are in mm

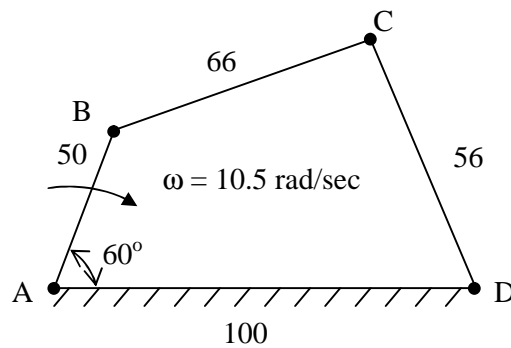

• **Solution:**

*Step 1:* Draw configuration diagram to a scale.

*Step 2:* Draw velocity vector diagram to a scale.

$$V_b = \omega_2 \times AB$$

$$V_b = 10.5 \times 0.05$$

$$V_b = 0.525 \text{ m/s}$$

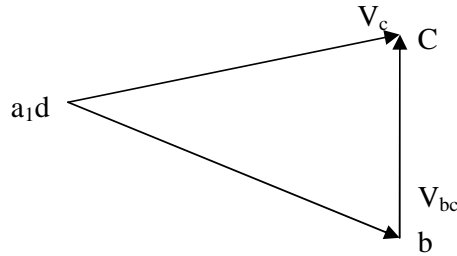

*Step 3:* Prepare a table as shown below:

Sl. No.	Link	Magnitude	Direction	Sense
1.	AB	$f^c = \omega_{AB}^2 r$ $f^c = (10.5)^2 / 0.525$ $f^c = 5.51 \text{ m/s}^2$	Parallel to AB	$\rightarrow A$
2.	BC	$f^c = \omega_{BC}^2 r$ $f^c = 1.75$ $f^t = \alpha r$	Parallel to BC  $\perp^r$ to BC	$\rightarrow B$  -
3.	CD	$f^c = \omega_{CD}^2 r$ $f^c = 2.75$ $f^t = ?$	Parallel to DC  $\perp^r$ to DC	$\rightarrow D$  -

*Step 4:* Draw the acceleration diagram.

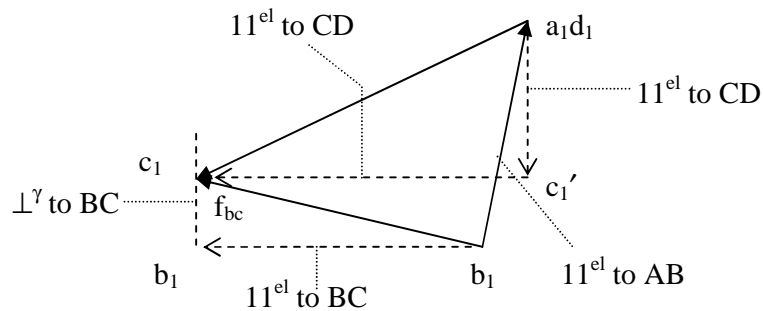

- Choose a suitable scale to draw acceleration diagram.
- Mark the zero acceleration point  $a_1d_1$ .
- Link AB has only centripetal acceleration. Therefore, draw a line parallel to AB and toward A from  $a_1d_1$  equal to  $5.51 \text{ m/s}^2$  i.e. point  $b_1$ .
- From  $b_1$  draw a vector parallel to BC points towards B equal to  $1.75 \text{ m/s}^2$  ( $b_1^1$ ).
- From  $b_1^1$  draw a line  $\perp^r$  to BC. The magnitude is not known.
- From  $a_1d_1$  draw a vector parallel to AD and pointing towards D equal to  $2.72 \text{ m/s}^2$  i.e. point  $c_1$ .
- From  $c_1^1$  draw a line  $\perp^r$  to CD to intersect the line drawn  $\perp^r$  to BC at  $c_1$ ,  
 $\overrightarrow{d_1c_1} = f_{CD}$  and  $\overrightarrow{b_1c_1} = f_{bc}$ .

To determine angular acceleration.

$$\alpha_{BC} = \frac{f_{bc}^t}{BC} = \frac{c_1b_1^1}{BC} = 34.09 \text{ rad/sec (CCW)}$$

$$\alpha_{CD} = \frac{f_{cd}^t}{CD} = \frac{c_1c_1^1}{CD} = 79.11 \text{ rad/sec (CCW)}$$

- **Problem 2:** For the configuration of slider crank mechanism shown in figure below.

Calculate

- Acceleration of slider B.
- Acceleration of point E.
- Angular acceleration of link AB.

If crank OA rotates at  $20 \text{ rad/sec}$  CCW.

- **Solution:**

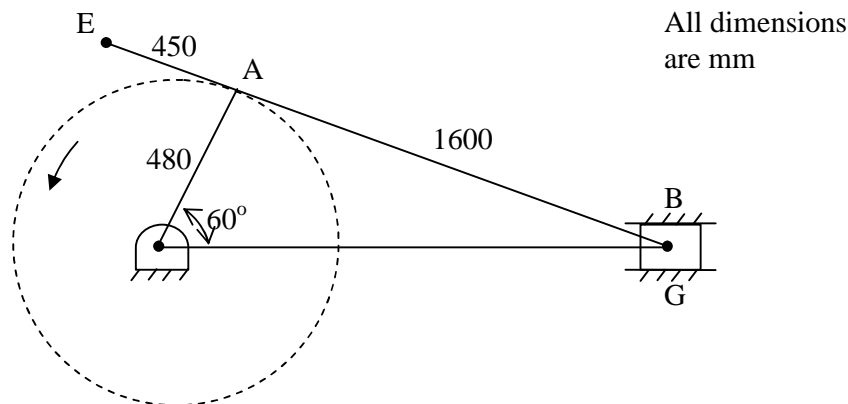

Step 1: Draw configuration diagram.

Step 2: Find velocity of A with respect to O.

$$V_a = \omega_{OA} \times OA$$

$$V_a = 20 \times 0.48$$

$$V_a = 9.6 \text{ m/s}$$

Step 4: Draw velocity vector diagram.

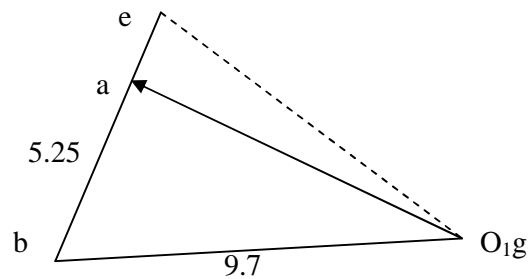

Step 4:

Sl. No.	Link	Magnitude	Direction	Sense
1.	OA	$f_{aO}^c = \omega_{OA}^2 r = 192$	Parallel to OA	$\rightarrow O$
2.	AB	$f_{ab}^c = \omega_{ab}^2 r = 17.2$ $f_{ab}^t$ —	Parallel to AB $\perp^r$ to AB	$\rightarrow A$ —
3.	Slider B	—	Parallel to Slider	—

Step 5: Draw the acceleration diagram choosing a suitable scale.

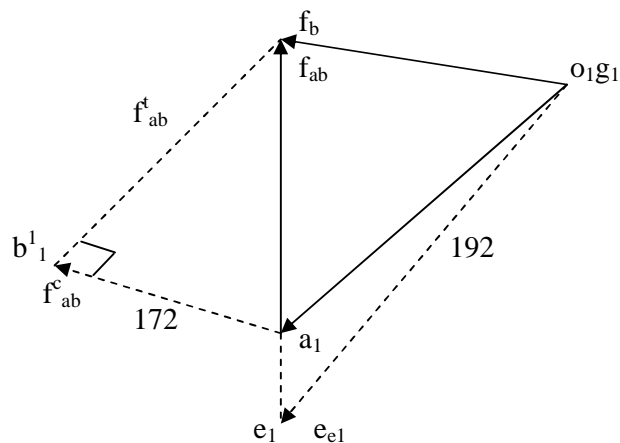

- Mark  $o_1g_1$  (zero acceleration point)
- Draw  $\overrightarrow{o_1g_1} = C$  acceleration of OA towards 'O'.
- From  $a_1$  draw  $a_1b_1^1 = 17.2 \text{ m/s}^2$  towards 'A' from  $b_1^1$  draw a line  $\perp^r$  to AB.
- From  $o_1g_1$  draw a line along the slider B to intersect previously drawn line at  $b_1$ ,  $\overrightarrow{a_1b_1} = f_{ab}$
- $\overrightarrow{g_1b_1} = f_b = 72 \text{ m/s}^2$ .
- Extend  $\overrightarrow{a_1b_1} = \overrightarrow{a_1e_1}$  such that  $\frac{\overrightarrow{a_1b_1}}{AB} = \frac{\overrightarrow{A_1R_1}}{AE}$ .
- Join  $e_1$  to  $\delta_1g_1$ ,  $\overrightarrow{g_1e_1} = f_e = 236 \text{ m/s}^2$ .
- $\alpha_{ab} = \frac{f_{ab}^t}{AB} = \frac{b_1b_1^t}{AB} = \frac{167}{1.6} = 104 \text{ rad/sec}^2$  (CCW).

**Answers:**

$$f_b = 72 \text{ m/sec}^2$$

$$f_e = 236 \text{ m/sec}^2$$

$$\alpha_{ab} = 104 \text{ rad/sec}^2$$

- **Problem 3:** In a toggle mechanism shown in figure the crank OA rotates at 210 rpm CCW increasing at the rate of  $60 \text{ rad/s}^2$ .
  - Velocity of slider D and angular velocity of link BD.
  - Acceleration of slider D and angular acceleration of link BD.

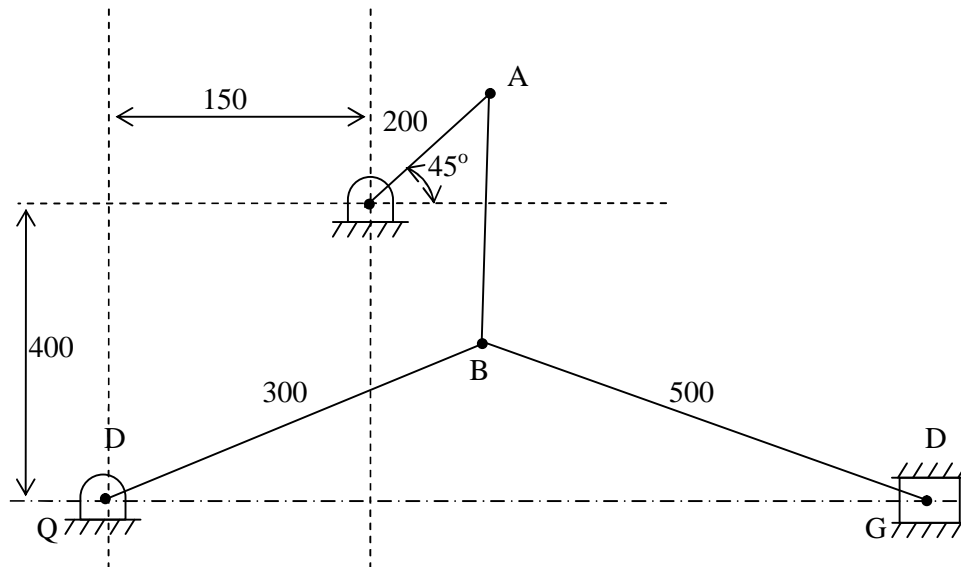

*Step 1* Draw the configuration diagram to a scale.

Step 2 Find

$$V_a = \omega_{OA} \times OA$$

$$V_a = \frac{2\pi(210)}{60} \times 0.2 = 4.4 \text{ m/s}$$

Step 3: Draw the velocity vector diagram.

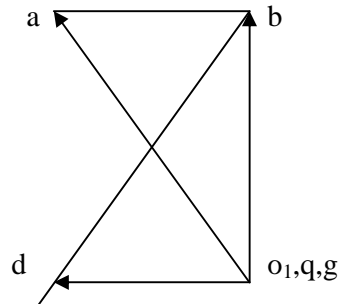

Step 4:

Sl. No.	Link	Magnitude $\text{m/s}^2$	Direction	Sense
1.	AO	$f_{aO}^c = \omega^2 r = 96.8$ $f_{aO}^t = \alpha r = 12$	Parallel to OA $\perp^r$ to OA	$\rightarrow O$ -
2.	AB	$f_{ab}^c = \omega^2 r = 5.93$ $f_{ab}^t = \alpha r =$	Parallel to AB $\perp^r$ to AB	$\rightarrow A$ -
3.	BQ	$f_{bq}^c = \omega^2 r = 38.3$ $f_{bq}^t = \alpha r =$	Parallel to BQ $\perp^r$ to BQ	$\rightarrow Q$ -
4.	BD	$f_{bd}^c = \omega^2 r = 20$	$\perp^r$ to BD	$\rightarrow B$
5.	Slider D	$f_{bd}^t = \alpha r =$ -	$\perp^r$ to BD Parallel to slider motion	- -

Step 5: Draw the acceleration diagram choosing a suitable scale.

- o Mark zero acceleration point.

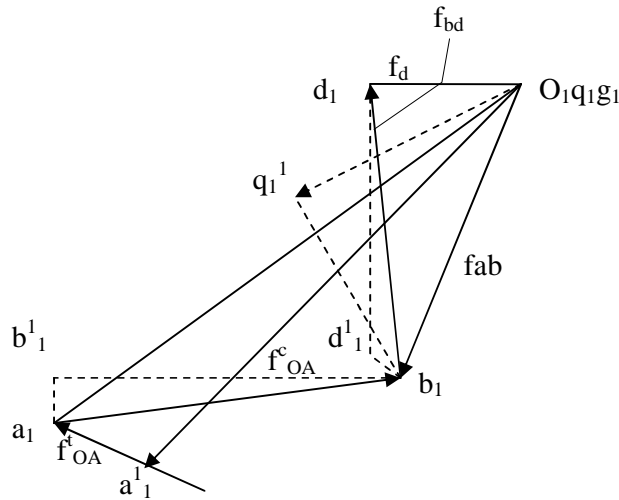

- Draw  $o_1 a_1^1 = f_{o_1 a_1}^c$  and  $a_1^1 a = f_{o_1 a_1}^t \perp^r$  to  $OA$  from
- $\overrightarrow{o_1 a_1} = f_a$
- From  $a_1$  draw  $\overrightarrow{a_1 b_1} = f_{a_1 b_1}^c$ , from  $b_1^1$  draw a line  $\perp^r$  to  $AB$ .
- From  $o_1 q_1 g_1$  draw  $\overrightarrow{o_1 q_1^1} = f_{o_1 q_1^1}^c$  and from  $q_1^1$  draw a line  $\perp^r$  to  $BQ$  to intersect the previously drawn line at  $b_1$
- $\overrightarrow{q_1 b_1} = f_{b_1 q_1}$        $\overrightarrow{a_1 b_1} = f_{ab}$
- From  $b_1$  draw a line parallel to  $BD = f_{bd}^c$  such that  $\overrightarrow{b_1 d_1^1} = f_{bd}^c$ .
- From  $d_1^1$  draw a line  $\perp^r$  to  $BD$ , from  $o_1 q_1 g_1$  draw a line along slider  $D$  to meet the previously drawn line at .
- $\overrightarrow{g_1 d_1} = f_d = 16.4 \text{ m/sec}^2$ .
- $\overrightarrow{b_1 d_1} = f_{bd} = 5.46 \text{ m/sec}^2$ .
- $\alpha_{BD} = \frac{f_{bd}}{BD} = \frac{5.46}{0.5} = 109.2 \text{ rad/sec}^2$

**Answers:**

$V_d = 2.54 \text{ m/s}$

$\omega_{bd} = 6.32 \text{ rad/s}$

$F_d = 16.4 \text{ m/s}^2$

$\alpha_{bd} = 109.2 \text{ rad/s}^2$

- **Coriolis Acceleration:** It has been seen that the acceleration of a body may have two components.
  - Centripetal acceleration and
  - Tangential acceleration.

However, in some cases there will be a third component called as coriolis acceleration to illustrate this let us take an example of crank and slotted lever mechanisms.

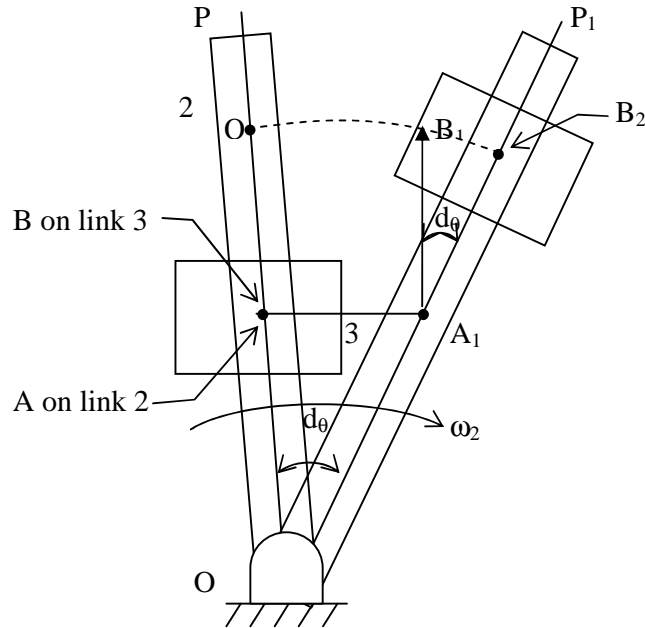

Assume link 2 having constant angular velocity  $\omega_2$ , in its motions from OP to OP<sub>1</sub> in a small interval of time  $\delta_t$ . During this time slider 3 moves outwards from position B to B<sub>2</sub>. Assume this motion also to have constant velocity  $V_{B/A}$ . Consider the motion of slider from B to B<sub>2</sub> in 3 stages.

1. B to A<sub>1</sub> due to rotation of link 2.
2. A<sub>1</sub> to B<sub>1</sub> due to outward velocity of slider  $V_{B/A}$ .
3. B<sub>1</sub> to B<sub>2</sub> due to acceleration  $\perp^t$  to link 2 this component in the coriolis component of acceleration.

$$\begin{aligned} \text{We have Arc } B_1B_2 &= \text{Arc } QB_2 - \text{Arc } QB_1 \\ &= \text{Arc } QB_2 - \text{Arc } AA_1 \end{aligned}$$

$$\begin{aligned} \therefore \text{Arc } B_1B_2 &= OQ \, d\theta - AO \, d\theta \\ &= A_1B_1 \, d\theta \\ &= V_{B/A} \, \omega_2 dt^2 \end{aligned}$$

The tangential component of velocity is  $\perp^r$  to the link and is given by  $V^t = \omega r$ . In this case  $\omega$  has been assumed constant and the slider is moving on the link with constant velocity. Therefore, tangential velocity of any point B on the slider 3 will result in uniform increase in tangential velocity. The equation  $V^t = \omega r$  remain same but r increases uniformly i.e. there is a constant acceleration  $\perp^r$  to rod.

$$\begin{aligned} \therefore \text{Displacement } B_1B_2 &= \frac{1}{2} at^2 \\ &= \frac{1}{2} f (dt)^2 \end{aligned}$$

$$\therefore \frac{1}{2} f (dt)^2 = V_{B/A} \omega_2 dt^2$$

$$\mathbf{f_{B/A}^{cr} = 2\omega_2 V_{B/A} \text{ coriolis acceleration}}$$

The direction of coriolis component is the direction of relative velocity vector for the two coincident points rotated at  $90^\circ$  in the direction of angular velocity of rotation of the link.

Figure below shows the direction of coriolis acceleration in different situation.

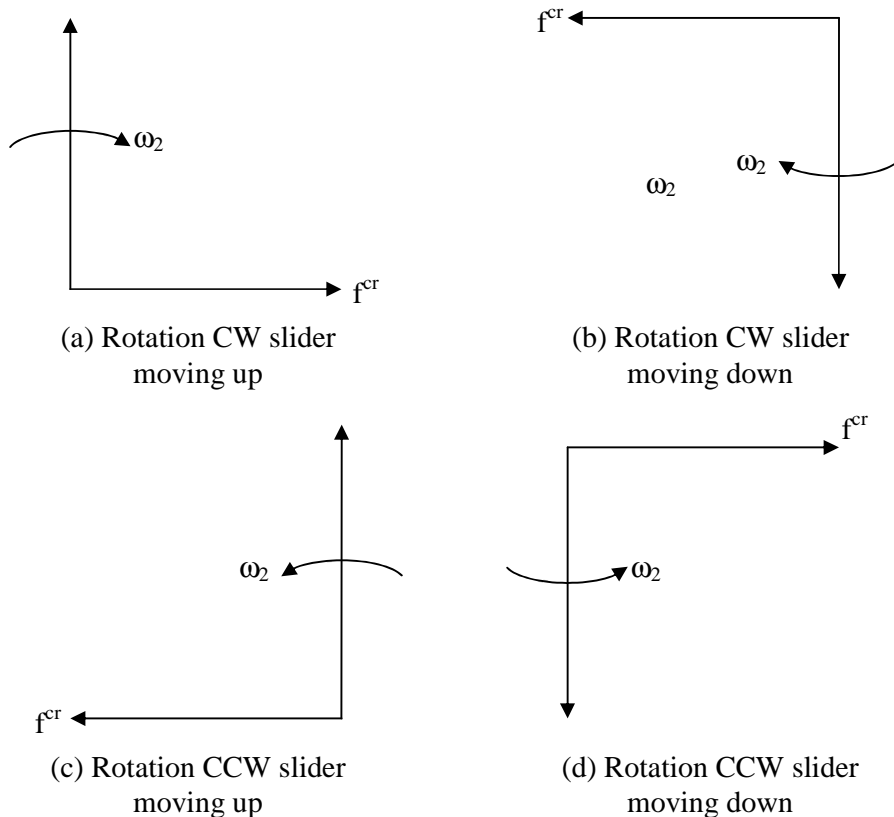

A quick return mechanism of crank and slotted lever type shaping machine is shown in Fig. the dimensions of various links are as follows.

$O_1O_2 = 800$  mm,  $O_1B = 300$  mm,  $O_2D = 1300$  mm and  $DR = 400$  mm

The crank  $O_1B$  makes an angle of  $45^\circ$  with the vertical and rotates at 40 rpm in the CCW direction. Find:

- iii) Acceleration of the Ram R, velocity of cutting tool, and
- iv) Angular Acceleration of link AD.

**Solution:**

**Step 1:** Draw the configuration diagram.

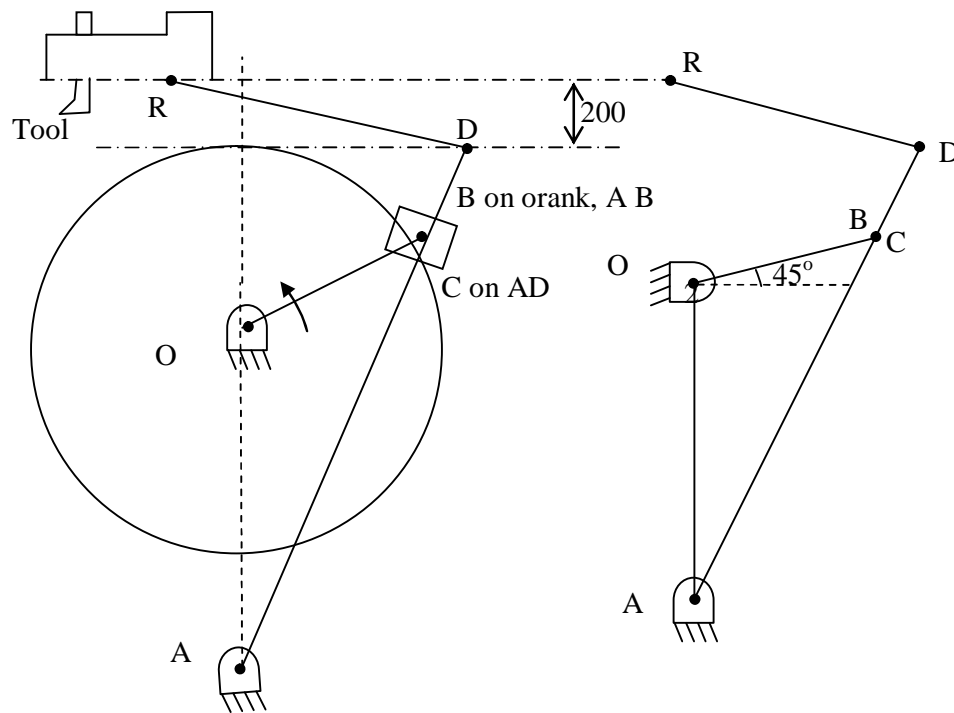

**Step 2:** Determine velocity of point B.

$$\mathbf{V}_b = \omega_{OB} \times \mathbf{OB}$$

$$\omega_{OB} = \frac{2\pi N_{O1B}}{60} = \frac{2\pi \times 40}{60} = 4.18 \text{ rad/sec}$$

$$\mathbf{V}_b = 4.18 \times 0.3 = 1.254 \text{ m/sec}$$

Step 3: Draw velocity vector diagram.

Choose a suitable scale 1 cm = 0.3 m/sec

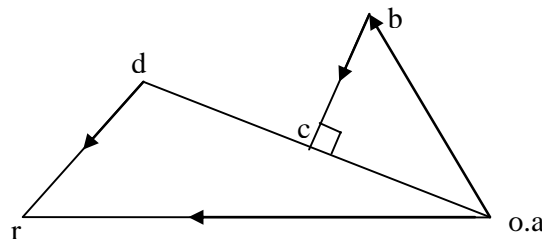

Step 4: prepare table showing the acceleration components

Sl. No.	Link	Magnitude $\text{m/s}^2$	Direction	Sense
1.	OB	$f_{ob}^c = \omega^2 r = 5.24$	Parallel to OB	$\rightarrow O$ -
2.	AC	$f_{ac}^c = \omega^2 r$ $f_{ac}^t = \alpha r$	Parallel to AB $\perp^r$ to AB	$\rightarrow A$ -
3.	BC	$f_{bc}^s = \alpha r$ $f_{bc}^{cc} = 2v\omega =$	Parallel to AB $\perp^r$ to AC	- -
4.	DR	$f_{bd}^c = \omega^2 r = 20$ $f_{bd}^t = \alpha r$	Parallel to DR $\perp^r$ to BD	$\rightarrow D$ -
5.	Slider R	$f_{bd}^t = \alpha r$	Parallel to slider motion	-

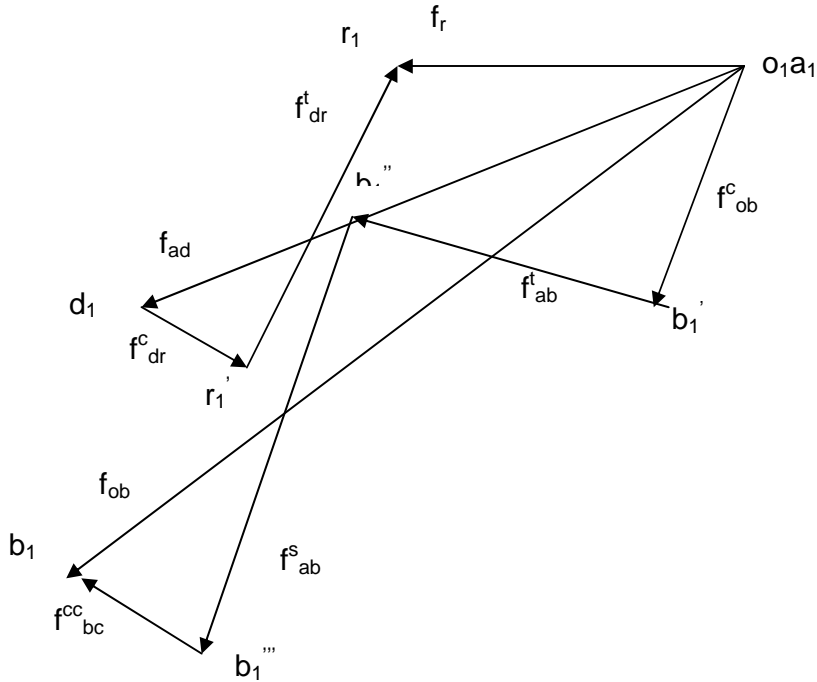

Acceleration of Ram =  $f_r = \omega_1^2 r$

Angular Acceleration of link AD

$$\alpha_{bd} = \frac{f_{bd}}{BD}$$

### KLENIN'S Construction

This method helps us to draw the velocity and acceleration diagrams on the construction diagram itself. The crank of the configuration diagram represents the velocity and acceleration line of the moving end (crank).

The procedure is given below for a slider crank mechanism.

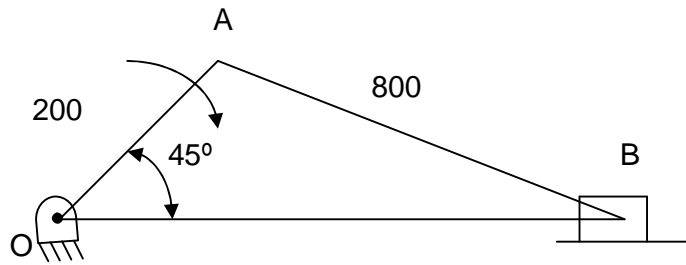

To draw the velocity vector diagram:

Link OA represents the velocity vector of A with respect to O.

$$V_{oa} = oa = r \cdot \omega = OA \cdot \omega$$

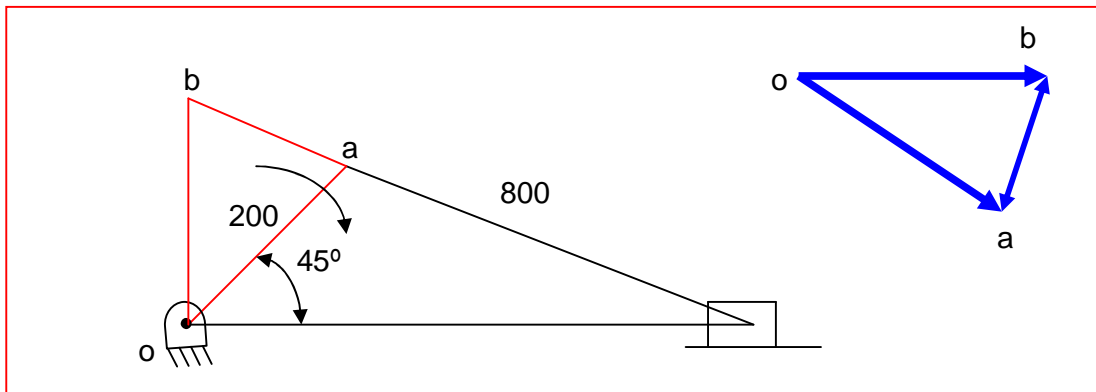

Draw a line perpendicular at O, extend the line BA to meet this perpendicular line at b. oab is the velocity vector diagram rotated through  $90^\circ$  opposite to the rotation of the crank.

Acceleration diagram:

The line representing Crank OA represents the acceleration of A with respect to O. To draw the acceleration diagram follow the steps given below.

- Draw a circle with OA as radius and A as centre.
- Draw another circle with AB as diameter.
- The two circles intersect each other at two points C and D.
- Join C and D to meet OB at  $b_1$  and AB at E.

$O_1, a_1, b_{a1}$  and  $b_1$  is the required acceleration diagram rotated through  $180^\circ$ .

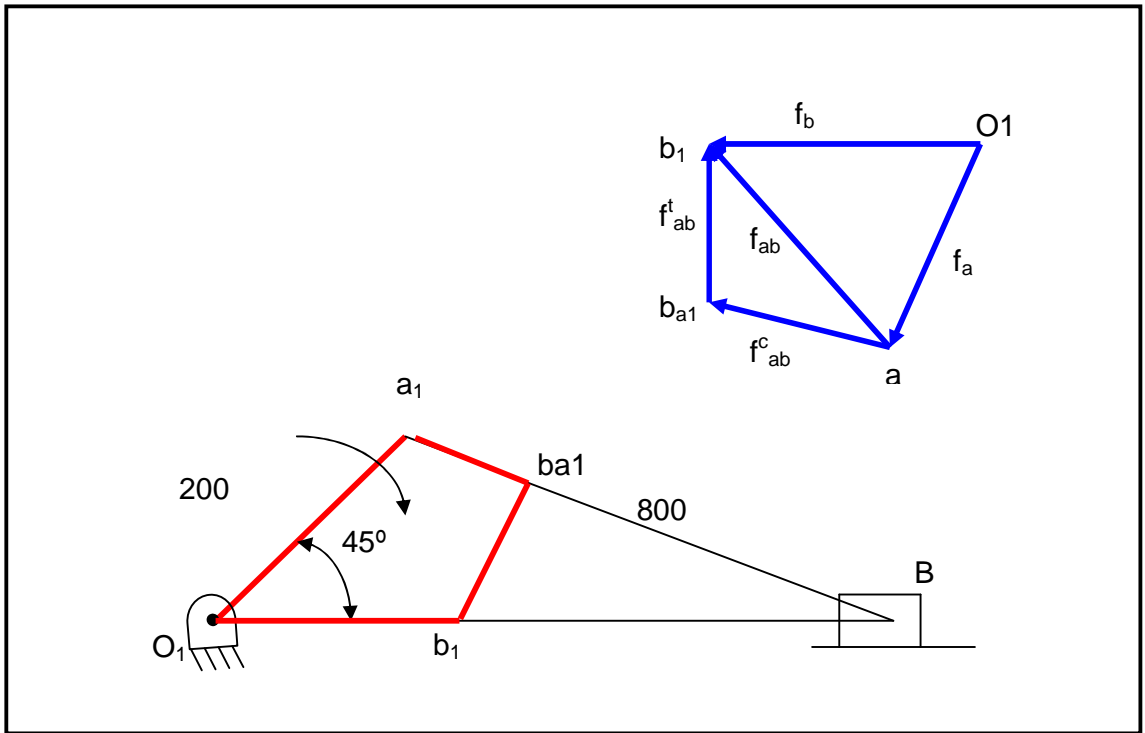

## Chapter 5: Gears Trains

A gear train is two or more gear working together by meshing their teeth and turning each other in a system to generate power and speed. It reduces speed and increases torque. To create large gear ratio, gears are connected together to form gear trains. They often consist of multiple gears in the train.

The most common of the gear train is the gear pair connecting parallel shafts. The teeth of this type can be spur, helical or herringbone. The angular velocity is simply the reverse of the tooth ratio.

Any combination of gear wheels employed to transmit motion from one shaft to the other is called a gear train. The meshing of two gears may be idealized as two smooth discs with their edges touching and no slip between them. This ideal diameter is called the Pitch Circle Diameter (PCD) of the gear.

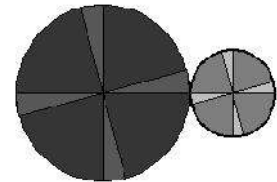

Copyright 1998 by Macmillan Irwin.

### Simple Gear Trains

The typical spur gears as shown in diagram. The direction of rotation is reversed from one gear to another. It has no affect on the gear ratio. The teeth on the gears must all be the same size so if gear A advances one tooth, so does B and C.

$t$  = number of teeth on the gear,

$D$  = Pitch circle diameter,  $N$  = speed in rpm

$$m = \text{module} = \frac{D}{t}$$

and

module must be the same for all

gears otherwise they would not mesh.

$$m = \frac{D_A}{t_A} = \frac{D_B}{t_B} = \frac{D_C}{t_C}$$

$$D_A = m t_A; \quad D_B = m t_B \quad \text{and} \quad D_C = m t_C$$

$\omega$  = angular velocity.

$$v = \text{linear velocity on the circle. } v = \omega \frac{D}{2} = \omega r$$

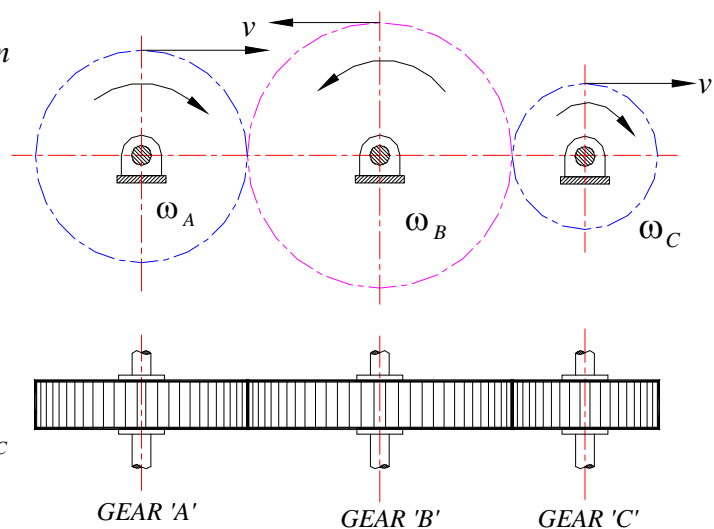

The velocity  $v$  of any point on the circle must be the same for all the gears, otherwise they would be slipping.

$$v = \omega_A \frac{D_A}{2} = \omega_B \frac{D_B}{2} = \omega_C \frac{D_C}{2}$$

$$\omega_A D_A = \omega_B D_B = \omega_C D_C$$

$$\omega_A m t_A = \omega_B m t_B = \omega_C m t_C$$

$$\omega_A t_A = \omega_B t_B = \omega_C t_C$$

or in terms of rev/min

$$N_A t_A = N_B t_B = N_C t_C$$

Application:

a) to connect gears where a large center distance is required

b) to obtain desired direction of motion of the driven gear ( CW or CCW)

c) to obtain high speed ratio

### Torque & Efficiency

The power transmitted by a torque  $T$  N-m applied to a shaft rotating at  $N$  rev/min is given by:

$$P = \frac{2\pi NT}{60}$$

In an ideal gear box, the input and output powers are the same so;

$$P = \frac{2\pi N_1 T_1}{60} = \frac{2\pi N_2 T_2}{60}$$

$$N_1 T_1 = N_2 T_2 \Rightarrow \frac{T_2}{T_1} = \frac{N_1}{N_2} = GR$$

It follows that if the speed is reduced, the torque is increased and vice versa. In a real gear box, power is lost through friction and the power output is smaller than the power input. The efficiency is defined as:

$$\eta = \frac{\text{Power out}}{\text{Power In}} = \frac{2\pi \times N_2 T_2 \times 60}{2\pi \times N_1 T_1 \times 60} = \frac{N_2 T_2}{N_1 T_1}$$

Because the torque in and out is different, a gear box has to be clamped in order to stop the case or body rotating. A holding torque  $T_3$  must be applied to the body through the clamps.

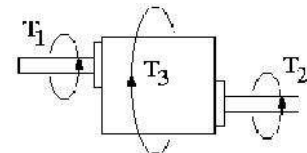

The total torque must add up to zero.

$$T1 + T2 + T3 = 0$$

If we use a convention that anti-clockwise is positive and clockwise is negative we can determine the holding torque. The direction of rotation of the output shaft depends on the design of the gear box.

### Compound Gear train

Compound gears are simply a chain of simple gear trains with the input of the second being the output of the first. A chain of two pairs is shown below. Gear B is the output of the first pair and gear C is the input of the second pair. Gears B and C are locked to the same shaft and revolve at the same speed. For large velocities ratios, compound gear train arrangement is preferred.

The velocity of each tooth on A and B are the same

so:  $\omega_A t_A = \omega_B t_B$  -as they are simple gears.

Likewise for C and D,  $\omega_C t_C = \omega_D t_D$ .

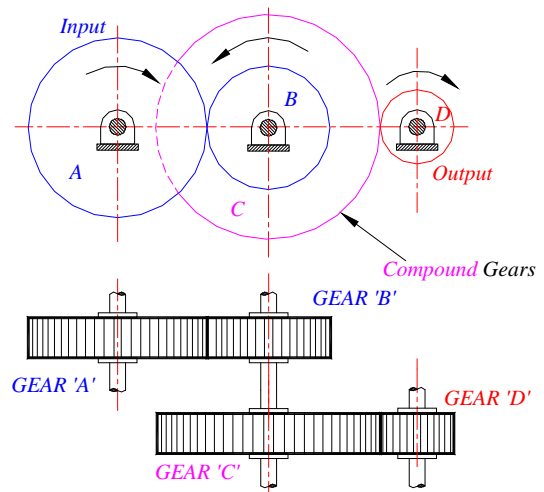

$$\frac{\omega_A}{t_B} = \frac{\omega_B}{t_A} \quad \text{and} \quad \frac{\omega_C}{t_D} = \frac{\omega_D}{t_C}$$

$$\omega_A = \frac{t_B \times \omega_B}{t_A} \quad \text{and} \quad \omega_C = \frac{t_D \times \omega_D}{t_C}$$

$$\omega_A \times \omega_C = \frac{t_B \times \omega_B}{t_A} \times \frac{t_D \times \omega_D}{t_C}$$

$$\frac{\omega_A \times \omega_C}{\omega_B \times \omega_D} = \frac{t_B}{t_A} \times \frac{t_D}{t_C}$$

Since gear B and C are on the same shaft

$$\omega_B = \omega_C$$

$$\frac{\omega_A}{\omega_D} = \frac{t_B}{t_A} \times \frac{t_D}{t_C} = GR$$

Since  $\omega = 2 \times \pi \times N$

The gear ratio may be

written as :

$$\frac{N(In)}{N(Out)} = \frac{t_B}{t_A} \times \frac{t_D}{t_C} = GR$$

### Reverted Gear train

The driver and driven axes lies on the same line. These are used in speed reducers, clocks and machine tools.

$$GR = \frac{N_A}{N_D} = \frac{t_B \times t_D}{t_A \times t_C}$$

If  $R$  and  $T$  = Pitch circle radius & number of teeth of the gear

$$R_A + R_B = R_C + R_D \quad \text{and} \quad t_A + t_B = t_C + t_D$$

***Epicyclic gear train:***

Epicyclic means one gear revolving upon and around another. The design involves planet and sun gears as one orbits the other like a planet around the sun. Here is a picture of a typical gear box.



This design can produce large gear ratios in a small space and are used on a wide range of applications from marine gearboxes to electric screwdrivers.

***Basic Theory***

The diagram shows a gear B on the end of an arm. Gear B meshes with gear C and revolves around it when the arm is rotated. B is called the planet gear and C the sun.

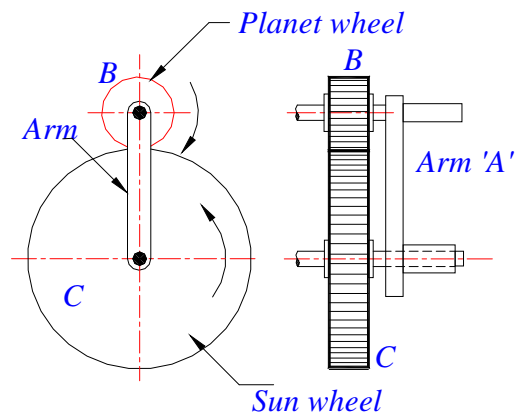

First consider what happens when the planet gear orbits the sun gear.

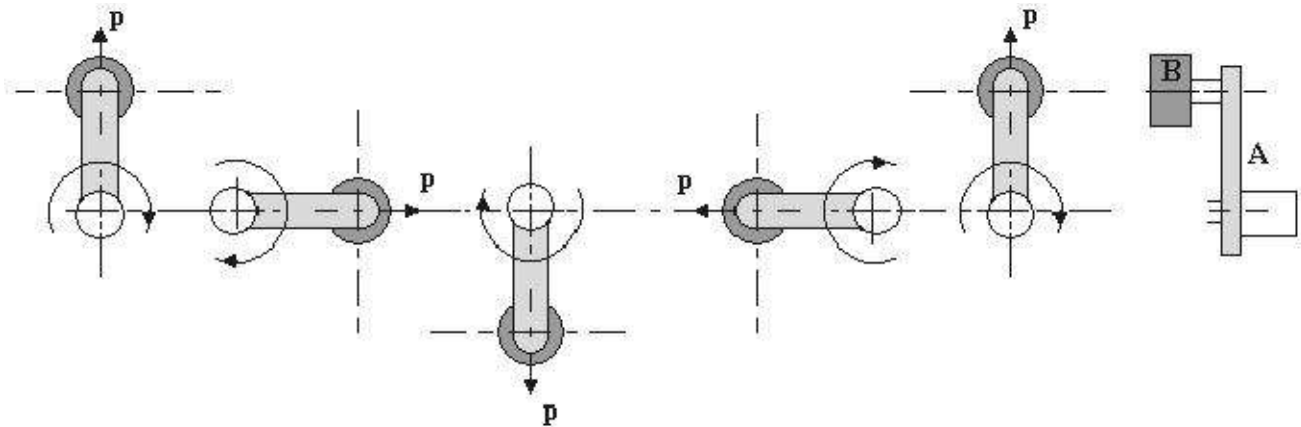

Observe point p and you will see that gear B also revolves once on its own axis. Any object orbiting around a center must rotate once. Now consider that B is free to rotate on its shaft and meshes with C. Suppose the arm is held stationary and gear C is rotated once. B spins about its own center and the number of revolutions it makes is the ratio  $\frac{t_C}{t_B}$ . B will rotate by this number for every complete revolution of C.

Now consider that C is unable to rotate and the arm A is revolved once. Gear B will revolve  $1 + \frac{t_C}{t_B}$  because of the orbit. It is this extra rotation that causes confusion. One way to get round this is to

imagine that the whole system is revolved once. Then identify the gear that is fixed and revolve it back one revolution. Work out the revolutions of the other gears and add them up. The following tabular method makes it easy.

Suppose gear  $C$  is fixed and the arm  $A$  makes one revolution. Determine how many revolutions the planet gear  $B$  makes.

Step 1 is to revolve everything once about the center.

Step 2 identify that  $C$  should be fixed and rotate it backwards one revolution keeping the arm fixed as it should only do one revolution in total. Work out the revolutions of  $B$ .

Step 3 is simply add them up and we find the total revs of  $C$  is zero and for the arm is 1.

<i>Step</i>	<i>Action</i>	<i>A</i>	<i>B</i>	<i>C</i>
1	Revolve all once	1	1	1
2	Revolve $C$ by $-1$ revolution, keeping the arm fixed	0	$+\frac{t_C}{t_B}$	-1
3	Add	1	$1+\frac{t_C}{t_B}$	0

The number of revolutions made by  $B$  is  $\left(1 + \frac{t_C}{t_B}\right)$  Note that if  $C$  revolves  $-1$ , then the direction of  $B$  is

opposite so  $+\frac{t_C}{t_B}$ .

**Example:** A simple epicyclic gear has a fixed sun gear with 100 teeth and a planet gear with 50 teeth. If the arm is revolved once, how many times does the planet gear revolve?

**Solution:**

<i>Step</i>	<i>Action</i>	<i>A</i>	<i>B</i>	<i>C</i>
1	Revolve all once	1	1	1
2	Revolve $C$ by $-1$ revolution, keeping the arm fixed	0	$+\frac{100}{50}$	-1
3	Add	<b>1</b>	<b>3</b>	<b>0</b>

**Gear B makes 3 revolutions for every one of the arm.**

The design so far considered has no identifiable input and output. We need a design that puts an input and output shaft on the same axis. This can be done several ways.

**Problem 1:** In an epicyclic gear train shown in figure, the arm A is fixed to the shaft S. The wheel B having 100 teeth rotates freely on the shaft S. The wheel F having 150 teeth driven separately. If the arm rotates at 200 rpm and wheel F at 100 rpm in the same direction; find (a) number of teeth on the gear C and (b) speed of wheel B.

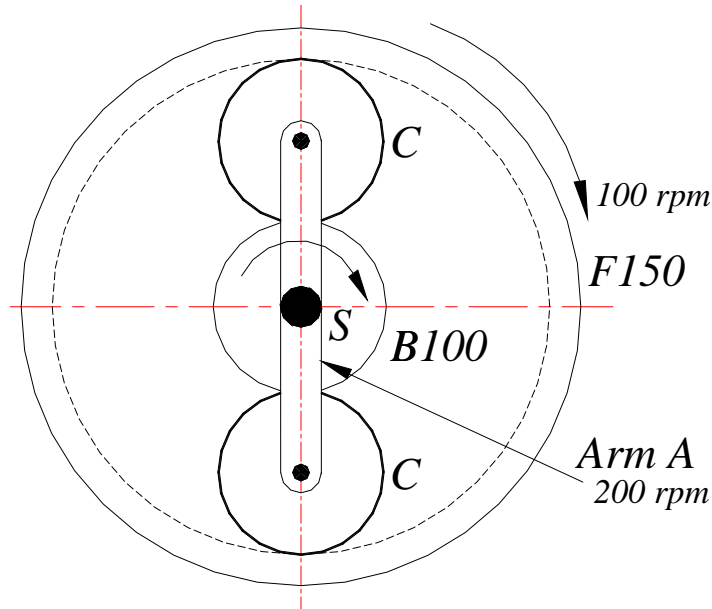

**Solution:**

$$T_B=100; \quad T_F=150; \quad N_A=200\text{rpm}; \quad N_F=100\text{rpm};$$

Since the module is same for all gears :

the number of teeth on the gears is proportional to the pitch circle :

$$\begin{aligned} \therefore r_F &= r_B + 2r_C \\ \Rightarrow T_F &= T_B + 2T_C \\ 150 &= 100 + 2 \times T_C \\ T_C &= 25 \rightarrow \text{Number of teeth on gears C} \end{aligned}$$

The gear B and gear F rotates in the opposite directions:

$$\begin{aligned} \therefore \text{Train value} &= -\frac{T_B}{T_F} \\ \text{also } TV &= \frac{N_L - N_{\text{Arm}}}{N_F - N_{\text{Arm}}} = \frac{N_F - N_A}{N_B - N_A} \quad (\text{general expression for epicyclic gear train}) \\ \therefore -\frac{T_B}{T_F} &= \frac{N_F - N_A}{N_B - N_A} \\ -\frac{100}{150} &= \frac{100 - 200}{N_B - 200} \quad \Rightarrow \quad N_B = 350 \end{aligned}$$

**The Gear B rotates at 350 rpm in the same direction of gears F and Arm A.**

**Problem 2:** In a compound epicyclic gear train as shown in the figure, has gears A and an annular gears D & E free to rotate on the axis P. B and C is a compound gear rotate about axis Q. Gear A rotates at 90 rpm CCW and gear D rotates at 450 rpm CW. Find the speed and direction of rotation of arm F and gear E. Gears A, B and C are having 18, 45 and 21 teeth respectively. All gears having same module and pitch.

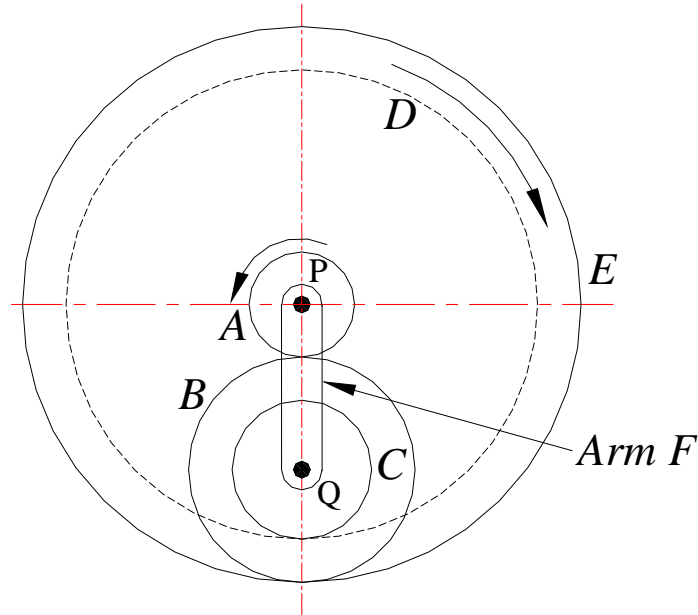

**Solution:**

$$T_A=18 ; \quad T_B=45; \quad T_C=21; \quad N_A = -90\text{rpm}; \quad N_D=450\text{rpm};$$

Since the module *and* pitch are same for all gears :

the number of teeth on the gears is proportional to the pitch circle :

$$\begin{aligned} \therefore r_D &= r_A + r_B + r_C \\ \Rightarrow T_D &= T_A + T_B + T_C \\ T_D &= 18 + 45 + 21 = 84 \text{ teeth on gear D} \end{aligned}$$

Gears A and D rotates in the opposite directions:

$$\therefore \text{Train value} = -\frac{T_A}{T_B} \times \frac{T_C}{T_D}$$

$$\text{also } TV = \frac{N_L - N_{Arm}}{N_F - N_{Arm}} = \frac{N_D - N_F}{N_A - N_F}$$

$$\therefore -\frac{T_A}{T_B} \times \frac{T_C}{T_D} = \frac{N_D - N_F}{N_A - N_F}$$

$$-\frac{18 \times 21}{45 \times 84} = \frac{450 - N_F}{-90 - N_F}$$

$$\Rightarrow N_F = \text{Speed of Arm} = 400.9 \text{ rpm} - \text{CW}$$

Now consider gears A, B and E:

$$\begin{aligned} r_E &= r_A + 2r_B \\ \Rightarrow T_E &= T_A + 2T_B \\ T_E &= 18 + 2 \times 45 \\ T_E &= 108 \rightarrow \text{Number of teeth on gear E} \end{aligned}$$

Gears A and E rotates in the opposite directions:

$$\begin{aligned} \therefore \text{Train value} &= -\frac{T_A}{T_E} \\ \text{also } TV &= \frac{N_E - N_F}{N_A - N_F} \\ \therefore -\frac{T_A}{T_E} &= \frac{N_E - N_F}{N_A - N_F} \\ -\frac{18}{108} &= \frac{N_E - 400.9}{-90 - 400.9} \\ \Rightarrow N_E &= \text{Speed of gear E} = 482.72 \text{ rpm} - \text{CW} \end{aligned}$$

**Problem 3:** In an epicyclic gear of sun and planet type shown in figure 3, the pitch circle diameter of the annular wheel A is to be nearly 216mm and module 4mm. When the annular ring is stationary, the spider that carries three planet wheels P of equal size to make *one revolution* for every *five revolution* of the driving spindle carrying the sun wheel.

Determine the number of teeth for all the wheels and the exact pitch circle diameter of the annular wheel. If an input torque of 20 N-m is applied to the spindle carrying the sun wheel, determine the fixed torque on the annular wheel.

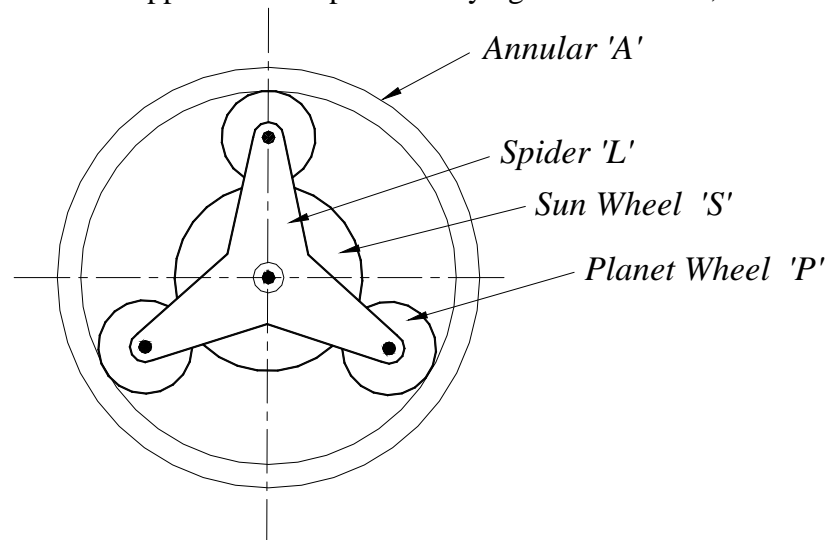

**Solution:** Module being the same for all the meshing gears:

$$\begin{aligned} T_A &= T_S + 2T_P \\ T_A &= \frac{\text{PCD of A}}{m} = \frac{216}{4} = 54 \text{ teeth} \end{aligned}$$

<i>Operation</i>	<i>Spider arm L</i>	Sun Wheel S $T_S$	Planet wheel P $T_P$	Annular wheel A $T_A = 54$
Arm L is fixed & Sun wheel S is given +1 revolution	0	+1	$-\frac{T_S}{T_P}$	$-\frac{T_S}{T_P} \times \frac{T_P}{T_A} = -\frac{T_S}{T_A}$
Multiply by m (S rotates through m revolution)	0	m	$-\frac{T_S}{T_P} m$	$-\frac{T_S}{T_A} m$
Add n revolutions to all elements	n	m+n	$n - \frac{T_S}{T_P} m$	$n - \frac{T_S}{T_A} m$

If L rotates +1 revolution:  $\therefore n = 1$  (1)

The sun wheel S to rotate +5 revolutions correspondingly:

$\therefore n + m = 5$  (2)

From (1) and (2)  $m = 4$

When A is fixed:

$$n - \frac{T_S}{T_A} m = 0 \quad \Rightarrow \quad T_A = 4T_S$$

$$\therefore T_S = \frac{54}{4} = 13.5 \text{ teeth}$$

But fractional teeth are not possible; therefore  $T_S$  should be either 13 or 14 and  $T_A$  correspondingly 52 and 56.

**Trial 1:** Let  $T_A = 52$  and  $T_S = 13$   
 $\therefore T_P = \frac{T_A - T_S}{2} = \frac{52 - 13}{4} = 19.5 \text{ teeth}$  - **This is impracticable**

**Trial 2:** Let  $T_A = 56$  and  $T_S = 14$   
 $\therefore T_P = \frac{T_A - T_S}{2} = \frac{56 - 14}{4} = 21 \text{ teeth}$  - **This is practicable**

$\therefore T_A = 56, T_S = 14$  and  $T_P = 21$

$\Rightarrow$  PCD of A =  $56 \times 4 = 224$  mm

Also

Torque on L  $\times \omega_L =$  Torque on S  $\times \omega_S$

Torque on L  $\times \omega_L = 20 \times \frac{5}{1} = 100 \text{ N-m}$

$\therefore$  Fixing torque on A =  $(T_L - T_S) = 100 - 20 = 80 \text{ N-m}$

**Problem 4:** The gear train shown in figure 4 is used in an indexing mechanism of a milling machine. The drive is from gear wheels A and B to the bevel gear wheel D through the gear train. The following table gives the number of teeth on each gear.

Gear	A	B	C	D	E	F
Number of teeth	72	72	60	30	28	24
Diametral pitch in mm	08	08	12	12	08	08

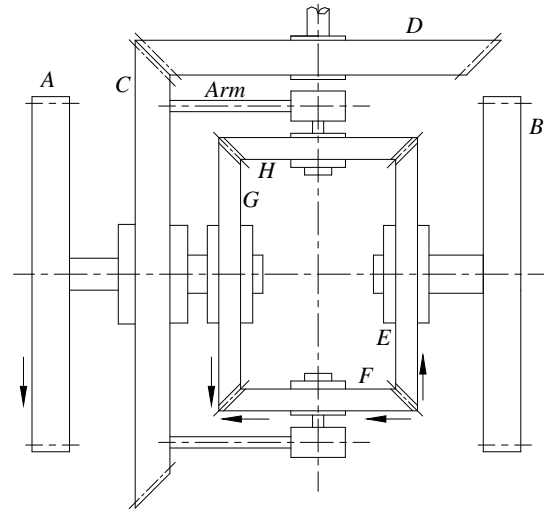

Figure 4

How many revolutions does D makes for one revolution of A under the following situations:

- If A and B are having the same speed and same direction
- If A and B are having the same speed and opposite direction
- If A is making 72 rpm and B is at rest
- If A is making 72 rpm and B 36 rpm in the same direction

**Solution:**

Gear D is external to the epicyclic train and thus C and D constitute an ordinary train.

Operation	Arm C (60)	E (28)	F (24)	A (72)	B (72)	G (28)	H (24)
Arm or C is fixed & wheel A is given +1 revolution	0	-1	$-\frac{28}{24} = -\frac{7}{6}$	+1	-1	+1	$\frac{28}{24} = \frac{7}{6}$
Multiply by m (A rotates through m revolution)	0	-m	$-\frac{7}{6}m$	+m	-m	+m	$\frac{7}{6}m$
Add n revolutions to all elements	n	n - m	$n - \frac{7}{6}m$	n + m	n - m	n + m	$n + \frac{7}{6}m$

- For one revolution of A:  $n + m = 1$  (1)  
 For A and B for same speed and direction:  $n + m = n - m$  (2)  
 From (1) and (2):  $n = 1$  and  $m = 0$

∴ If C or arm makes one revolution, then revolution made by D is given by:

$$\frac{N_D}{N_C} = \frac{T_C}{T_D} = \frac{60}{30} = 2$$

$$\therefore N_D = 2N_C$$

- A and B same speed, opposite direction:  $(n + m) = -(n - m)$  (3)  
 $n = 0$ ;  $m = 1$

∴ When C is fixed and A makes one revolution, D does not make any revolution.

(iii) A is making 72 rpm:  $(n + m) = 72$   
 B at rest  $(n - m) = 0 \Rightarrow n = m = 36 \text{ rpm}$   
 $\therefore$  C makes 36 rpm and D makes  $36 \times \frac{60}{30} = 72 \text{ rpm}$

(iv) A is making 72 rpm and B making 36 rpm  
 $(n + m) = 72 \text{ rpm}$  and  $(n - m) = 36 \text{ rpm}$   
 $(n + (n - m)) = 72; \Rightarrow n = 54$   
 $\therefore$  D makes  $54 \times \frac{60}{30} = 108 \text{ rpm}$

**Problem 5:** Figure 5 shows a compound epicyclic gear train, gears  $S_1$  and  $S_2$  being rigidly attached to the shaft  $Q$ . If the shaft  $P$  rotates at 1000 rpm clockwise, while the annular  $A_2$  is driven in counter clockwise direction at 500 rpm, determine the speed and direction of rotation of shaft  $Q$ . The number of teeth in the wheels are  $S_1 = 24$ ;  $S_2 = 40$ ;  $A_1 = 100$ ;  $A_2 = 120$ .

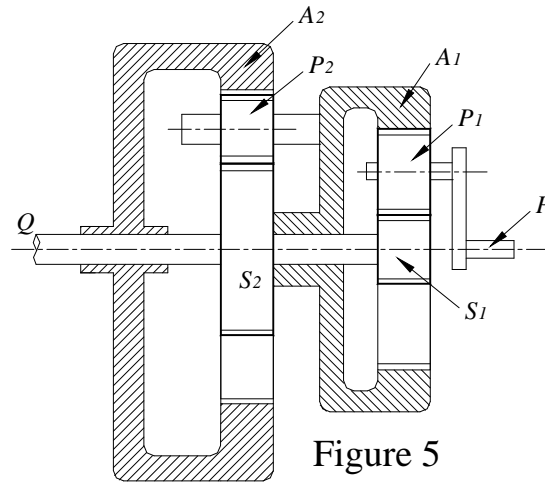

Figure 5

**Solution:** Consider the gear train  $P A_1 S_1$ :

Operation	Arm P	$A_1$ (100)	$S_1$ (24)
Arm P is fixed & wheel $A_1$ is given +1 revolution	0	+1	$+\frac{100}{P_1} \times -\frac{P_1}{24}$ $= -\frac{25}{6}$
Multiply by $m$ ( $A_1$ rotates through $m$ revolution)	0	$+m$	$-\frac{25}{6}m$
Add $n$ revolutions to all elements	$n$	$n+m$	$n - \frac{25}{6}m$

OR

Operation	Arm P	$A_1$ (100)	$S_1$ (24)
Arm P is fixed & wheel $A_1$ is given -1 revolution	0	-1	$-\frac{A_1}{P_1} \times -\frac{P_1}{S_1}$ $= +\frac{A_1}{S_1}$
	0	-1	$\frac{100}{24} = \frac{25}{6}$
Add +1 revolutions to all elements	+1	0	$\frac{25}{6} + 1 = \frac{31}{6}$

If  $A_1$  is fixed:  $n + m$ ; gives  $n = -m$

$$\frac{N_P}{N_{S1}} = \frac{n}{n + \frac{25}{6}n} = \frac{1}{\frac{31}{6}} = \frac{6}{31}$$

$$\therefore N_P = \frac{6}{31} N_{S1}$$

Now consider whole gear train:

Operation	A <sub>1</sub> (100)	A <sub>2</sub> (120)	S <sub>1</sub> (24), S <sub>2</sub> (40) and Q	Arm P
A <sub>1</sub> is fixed & wheel A <sub>2</sub> is given +1 revolution	0	+1	$+\frac{120}{P_2} \times -\frac{P_2}{40}$ $= -3$	$-3 \times \frac{6}{31}$ $= -\frac{18}{31}$
Multiply by $m$ (A <sub>1</sub> rotates through $m$ revolution)	0	$+m$	$-3m$	$-\frac{18}{31}m$
Add $n$ revolutions to all elements	$n$	$n+m$	$n-3m$	$n-\frac{18}{31}m$

When  $P$  makes 1000 rpm:  $n - \frac{18}{31}m = 1000$  (1)

and  $A_2$  makes  $-500$  rpm:  $n + m = -500$  (2)

from (1) and (2):  $-500 - m - \frac{18}{31}m = 1000$

$$(31 \times 1000) + (500 \times 31) = -49m$$

$$\therefore m = -949 \text{ rpm}$$

$$\text{and } n = 949 - 500 = 449 \text{ rpm}$$

$$\therefore N_Q = n - 3m = 449 - (3 \times -949) = 3296 \text{ rpm}$$

**Problem 6.** An internal wheel B with 80 teeth is keyed to a shaft F. A fixed internal wheel C with 82 teeth is concentric with B. A Compound gears D-E meshed with the two internal wheels. D has 28 teeth and meshes with internal gear C while E meshes with B. The compound wheels revolve freely on pin which projects from a arm keyed to a shaft A co-axial with F. if the wheels have the same pitch and the shaft A makes 800 rpm, what is the speed of the shaft F? Sketch the arrangement.

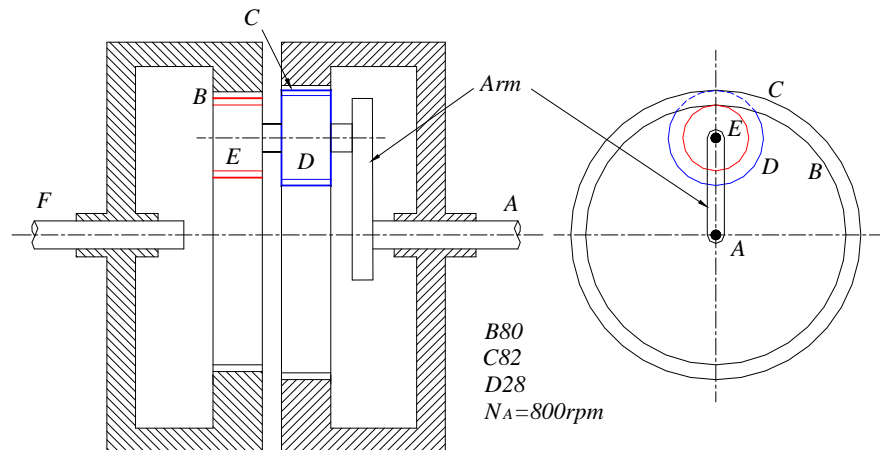

**Data:**  $t_B = 80$ ;  $t_C = 82$ ;  $D = 28$ ;  $N_A = 800 \text{ rpm}$

**Solution:** The pitch circle radius is proportional to the number of teeth:

$$r_C - r_D = r_B - r_E$$

$$t_C - t_D = t_B - t_E$$

$$82 - 28 = 80 - t_E$$

$$t_E = 26$$

– number of teeth on gear E

Operation	Arm	B (80)	Compound Gear wheel		C (82)
			E(26)	D (28)	
Arm is fixed & B is given ONE revolution (CW)	0	+1	$+\frac{80}{26}$	$+\frac{80}{26}$	$+\frac{80}{26} \times \frac{28}{82}$
Multiply by m (B rotates through m revolution)	0	+m	$+\frac{40}{13}m$	$+\frac{40}{13}m$	$+\frac{40}{13} \times \frac{14}{41}m$
Add n revolutions to all elements	n	m+n	$\frac{40}{13}m+n$	$\frac{40}{13}m+n$	$\frac{40}{13} \times \frac{14}{41}m+n$

Since the wheel C is fixed and the arm (shaft) A makes 800 rpm,

$$\Rightarrow n = 800 \text{ rpm}$$

$$\frac{40}{13} \times \frac{14}{41} m + n = 0$$

$$\frac{40}{13} \times \frac{14}{41} m + 800 = 0$$

$$m = -761.42 \text{ rpm}$$

$$\text{Speed of gear B} = m + n = -761.42 + 800 = 38.58 \text{ rpm}$$

$$\text{Speed of gear B} = \text{Speed of shaft F} = 38.58 \text{ rpm}$$

**Problem 7:** The fig shows an Epicyclic gear train. Wheel E is fixed and wheels C and D are integrally cast and mounted on the same pin. If arm A makes one revolution per sec (Counter clockwise) determine the speed and direction of rotation of the wheels B and F.

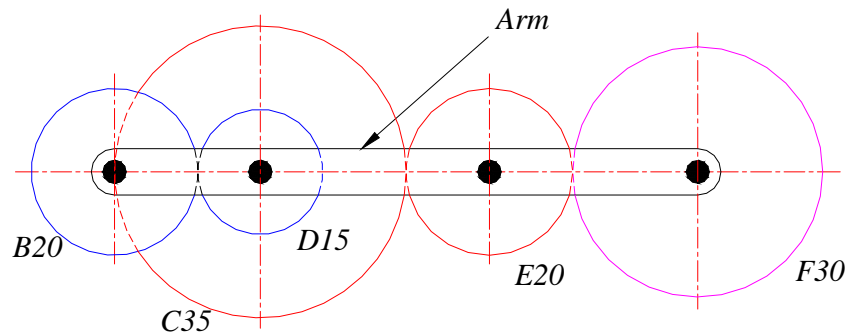

**Solution:**

**Data:**  $t_B = 20$ ;  $t_C = 35$ ;  $t_D = 15$ ;  $t_E = 20$ ;  $t_F = 30$   $N_A = 1 \text{ rps} \text{-(CCW)}$

Operation	Arm	B (20)	Compound Gear wheel		E (20)	F (30)
			D (15)	C (35)		
Arm is fixed & B is given ONE revolution (CW)	0	+1	$-\frac{20}{15}$	$-\frac{20}{15}$	$-\frac{4}{3} \times -\frac{35}{20} = +\frac{7}{3}$	$\frac{7}{3} \times -\frac{20}{30}$
Multiply by m (B rotates through m revolution)	0	+m	$-\frac{4}{3}m$	$-\frac{4}{3}m$	$\frac{7}{3}m$	$-\frac{14}{9}m$
Add n revolutions to all elements	n	m+n	$n - \frac{4}{3}m$	$n - \frac{4}{3}m$	$\frac{7}{3}m + n$	$n - \frac{14}{9}m$

Since the wheel E is fixed and the arm A makes 1 rps-CCW

$$\Rightarrow \quad n = -1 \text{ rps} \quad \text{and} \quad \frac{7}{3}m + n = 0$$

$$\frac{7}{3}m - 1 = 0 \quad \Rightarrow \quad m = \frac{3}{7} = 0.429$$

$$\text{Speed of gear B} = m + n = 0.429 - 1 = -0.571 \text{ rps (CCW)}$$

$$\text{Speed of gear F} = n - \frac{14}{9}m = -1 - \frac{14}{9} \times 0.429 = -1.667 \text{ (CCW)}$$

**Problem 7:** In the gear train shown, the wheel C is fixed, the gear B, is keyed to the input shaft and the gear F is keyed to the output shaft.

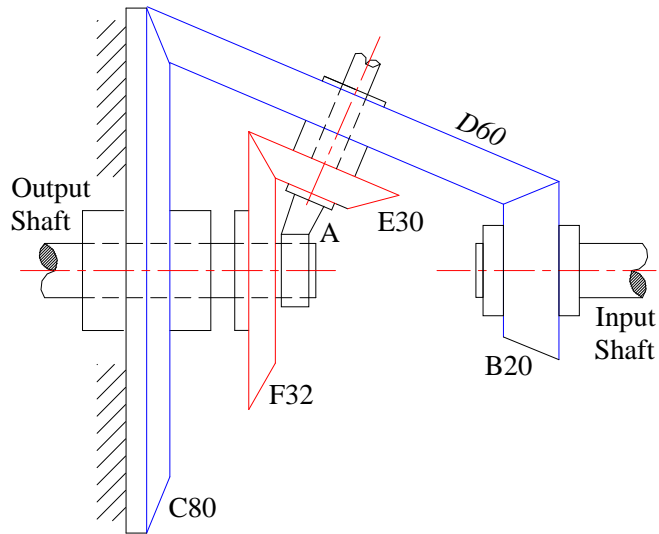

The arm A, carrying the compound wheels D and E turns freely on the out put shaft. If the input speed is 1000 rpm (ccw) when seen from the right, determine the speed of the output shaft. The number of teeth on each gear is indicated in the figures. Find the output torque to keep the wheel C fixed if the input power is 7.5 kW.

**Solution:**

**Data :**

$$t_B = 20; t_C = 80; t_D = 60; t_E = 30; t_F = 32; N_B = 1000 \text{ rpm (ccw) (input speed); } P = 7.5 \text{ kW}$$

Operation	Arm	B (20) Input	Compound Gear wheel		C (80)	F (32)
			D (60)	E (30)		
Arm is fixed & B is given +1 revolution	0	+1	$\frac{20}{60} = \frac{1}{3}$	$\frac{1}{3}$	$\frac{1}{3} \times -\frac{60}{80} = -\frac{1}{4}$	$\frac{1}{3} \times -\frac{30}{32} = -\frac{5}{16}$
Multiply by m (B rotates through m revolution)	0	m	$\frac{1}{3}m$	$\frac{1}{3}m$	$-\frac{1}{4}m$	$-\frac{5}{16}m$
Add n revolutions to all elements	n	m+n	$\frac{1}{3}m+n$	$\frac{1}{3}m+n$	$n - \frac{1}{4}m$	$n - \frac{5}{16}m$

Input shaft speed = 1000 rpm (ccw)  
i.e., gear B rotates – 1000 rpm

$$m + n = -1000$$

$$\text{Gear C is fixed; } n - \frac{1}{4}m = 0$$

$$-1000 - m - 0.25m = 0$$

$$m = -\frac{1000}{1.25} = -800$$

$$n = -1000 + 800 = -200$$

$$\begin{aligned} \text{Speed of F} &= n - \frac{5}{16}m \\ &= -200 + 800 \frac{5}{16} = 50 \end{aligned}$$

Speed of the output shaft F = +50rpm (CW)

$$\begin{aligned} \text{Input power} = P &= \frac{2 \times \pi \times N_B T_B}{60} \\ 7.5 \times 1000 &= \frac{2 \times \pi \times -1000 \times T_B}{60} \\ T_B &= -\frac{7500 \times 60}{2 \times \pi \times 1000} = -71.59 \text{ Nm} \end{aligned}$$

From the energy equation;

$$T_B N_B + T_F N_F + T_C N_C = 0$$

Since C is fixed :  $N_C = 0$

$$T_B N_B + T_F N_F = 0$$

$$-71.59 \times 1000 + T_F \times 50 = 0$$

$$T_F = +1431.8 \text{ Nm}$$

From the torque equation :

$$T_B + T_F + T_C = 0$$

$$-71.59 + 1431.8 + T_C = 0$$

$$\therefore T_C = -1360.21 \text{ Nm}$$

The Torque required to hold the wheel C = 1360.21 Nm in the same direction of wheel

---

**Problem 8:** Find the velocity ratio of two co-axial shafts of the epicyclic gear train as shown in figure 6.  $S_1$  is the driver. The number of teeth on the gears are  $S_1 = 40$ ,  $A_1 = 120$ ,  $S_2 = 30$ ,  $A_2 = 100$  and the sun wheel  $S_2$  is fixed. Determine also the magnitude and direction of the torque required to fix  $S_2$ , if a torque of 300 N-m is applied in a clockwise direction to  $S_1$

**Solution:** Consider first the gear train  $S_1, A_1$  and  $A_2$  for which  $A_2$  is the arm, in order to find the speed ratio of  $S_1$  to  $A_2$ , when  $A_1$  is fixed.

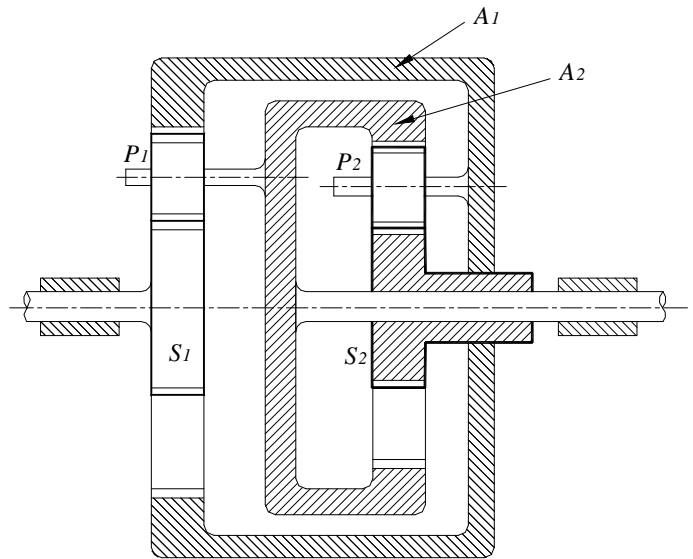

Figure 6

(a) Consider gear train  $S_1, A_1$  and  $A_2$ :

Operation	$A_2$ (100)	$A_1$ (120)	$S_1$ (40)
$A_2$ is fixed & wheel $A_1$ is given +1 revolution	0	+1	$-\frac{120}{40} = -3$
Multiply by $m$ ( $A_1$ rotates through $m$ revolution)	0	$+m$	$-3m$
Add $n$ revolutions to all elements	$n$	$n + m$	$n - 3m$

$A_1$  is fixed:  $m = -n$

$$\frac{N_{S_1}}{N_{A_2}} = \frac{n + 3n}{n} = 4$$

$$\therefore N_{S_1} = 4 N_{A_2}$$

(b) Consider complete gear train:

Operation	$A_1$ (120)	$A_2$ (100)	$S_1$ (40)	$S_2$ (30)
$A_1$ is fixed & wheel $S_2$ is given +1 revolution	0	$-\frac{30}{100} = -\frac{3}{10}$	$-\frac{3}{10} \times 4 = -\frac{6}{5}$	+1
Multiply by $m$ ( $A_1$ rotates through $m$ revolution)	0	$= -\frac{3}{10}m$	$-\frac{6}{5}m$	$+m$
Add $n$ revolutions to all elements	$n$	$n - \frac{3}{10}m$	$n - \frac{6}{5}m$	$n + m$

$$S_2 \text{ is fixed} \Rightarrow m = -n$$

$$\frac{N_{S1}}{N_{A2}} = \frac{n + \frac{6}{5}n}{n + \frac{3}{10}n} = \frac{11}{5} \times \frac{10}{13} = \frac{22}{13}$$

Input torque on  $S_1 = T_{S1} = 300 \text{ N-m}$ , in the direction of rotation.

$\therefore$  Resisting torque on  $A_2$ ;

$$T_{A2} = 300 \times \frac{22}{13} = 507.7 \text{ N-m}$$

$\rightarrow$  opposite to direction of rotation

$\therefore$  Referring to the figure:

$$T_{S2} = 507.7 - 300 = 207.7 \text{ N-m} \quad (CW)$$

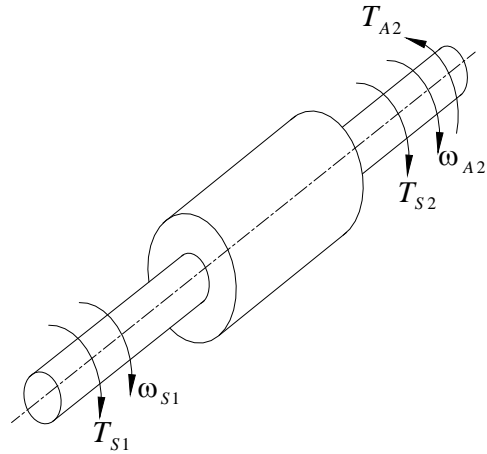

## Chapter VI

### CAMS

#### INTRODUCTION

A cam is a mechanical device used to transmit motion to a follower by direct contact. The driver is called the cam and the driven member is called the follower. In a cam follower pair, the cam normally rotates while the follower may translate or oscillate. A familiar example is the camshaft of an automobile engine, where the cams drive the push rods (the followers) to open and close the valves in synchronization with the motion of the pistons.

#### Types of cams

Cams can be classified based on their physical shape.

**a) Disk or plate cam (Fig. 6.1a and b):** The disk (or plate) cam has an irregular contour to impart a specific motion to the follower. The follower moves in a plane perpendicular to the axis of rotation of the camshaft and is held in contact with the cam by springs or gravity.

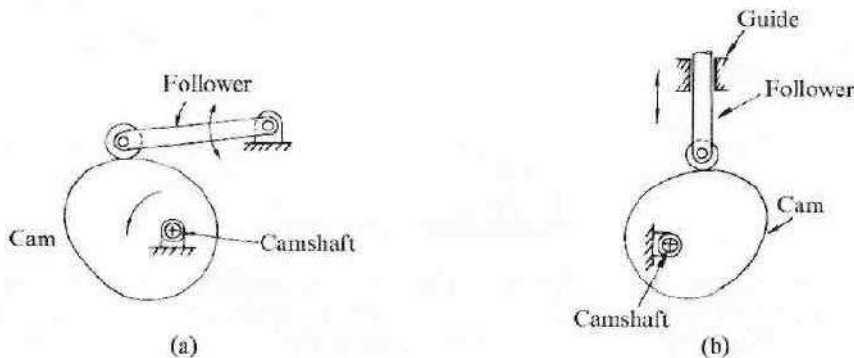

Fig. 6.1 Plate or disk cam.

**b) Cylindrical cam (Fig. 6.2):** The cylindrical cam has a groove cut along its cylindrical surface. The roller follows the groove, and the follower moves in a plane parallel to the axis of rotation of the cylinder.

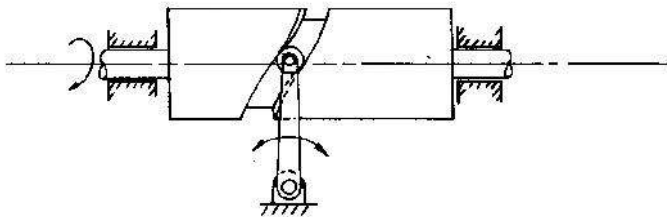

Fig. 6.2 Cylindrical cam.

**c) Translating cam (Fig. 6.3a and b).** The translating cam is a contoured or grooved plate sliding on a guiding surface(s). The follower may oscillate (Fig. 6.3a) or reciprocate (Fig. 6.3b). The contour or the shape of the groove is determined by the specified motion of the follower.

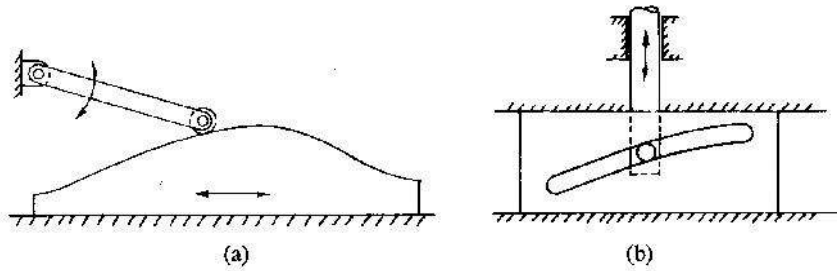

Fig. 6.3 Translating cam

**Types of followers:**

(i) Based on surface in contact. **(Fig.6.4)**

- (a) Knife edge follower
- (b) Roller follower
- (c) Flat faced follower
- (d) Spherical follower

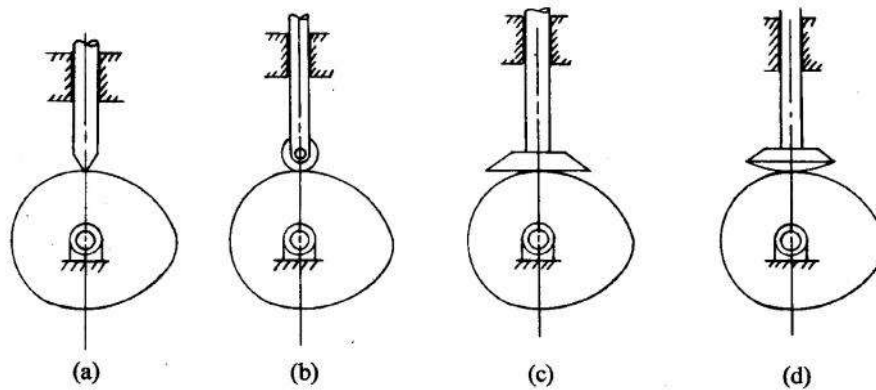

Fig. 6.4 Types of followers

(ii) Based on type of motion: **(Fig.6.5)**

- (a) Oscillating follower
- (b) Translating follower

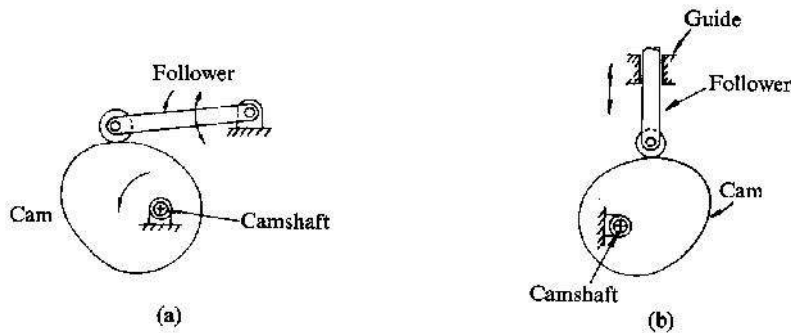

Fig.6.5

(iii) Based on line of motion:

- (a) Radial follower: The lines of movement of in-line cam followers pass through the centers of the camshafts (Fig. 6.4a, b, c, and d).
- (b) Off-set follower: For this type, the lines of movement are offset from the centers of the camshafts (Fig. 6.6a, b, c, and d).

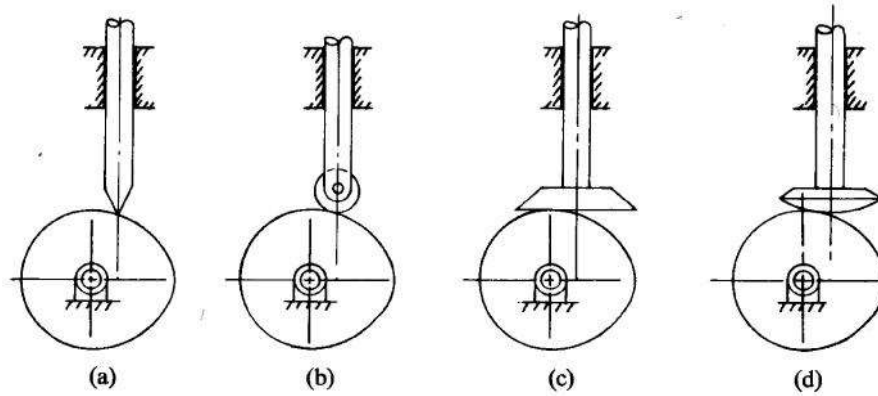

Fig.6.6 Off set followers

**Cam nomenclature (Fig. 6.7):**

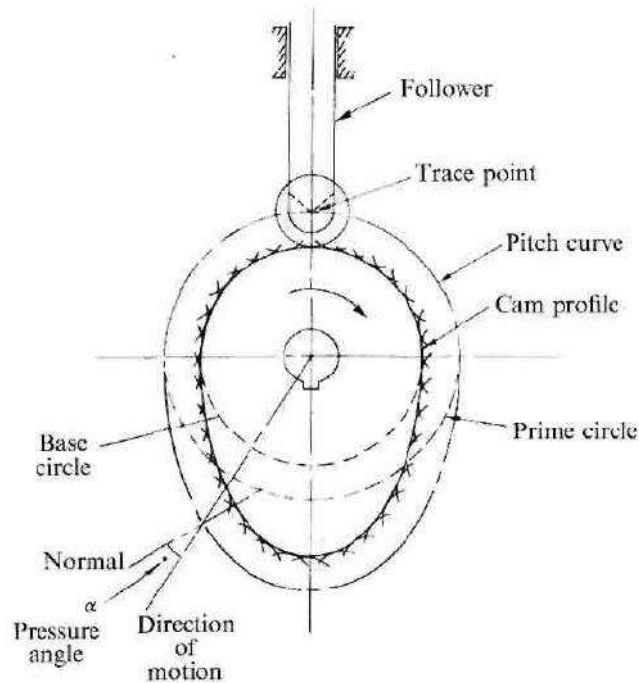

Fig.6.7

*Cam Profile* The contour of the working surface of the cam.

*Tracer Point* The point at the knife edge of a follower, or the center of a roller, or the center of a spherical face.

*Pitch Curve* The path of the tracer point.

*Base Circle* The smallest circle drawn, tangential to the cam profile, with its center on the axis of the camshaft. The size of the base circle determines the size of the cam.

*Prime Circle* The smallest circle drawn, tangential to the pitch curve, with its center on the axis of the camshaft.

*Pressure Angle* The angle between the normal to the pitch curve and the direction of motion of the follower at the point of contact.

### **Types of follower motion:**

Cam follower systems are designed to achieve a desired oscillatory motion. Appropriate displacement patterns are to be selected for this purpose, before designing the cam surface. The cam is assumed to rotate at a constant speed and the follower raises, dwells, returns to its original position and dwells again through specified angles of rotation of the cam, during each revolution of the cam.

Some of the standard follower motions are as follows:

They are, follower motion with,

- (a) Uniform velocity
- (b) Modified uniform velocity
- (c) Uniform acceleration and deceleration
- (d) Simple harmonic motion
- (e) Cycloidal motion

**Displacement diagrams:** In a cam follower system, the motion of the follower is very important. Its displacement can be plotted against the angular displacement of the cam and it is called as the displacement diagram. The displacement of the follower is plotted along the y-axis and angular displacement of the cam is plotted along x-axis. From the displacement diagram, velocity and acceleration of the follower can also be plotted for different angular displacements of the cam. The displacement, velocity and acceleration diagrams are plotted for one cycle of operation i.e., one rotation of the cam. Displacement diagrams are basic requirements for the construction of cam profiles. Construction of displacement diagrams and calculation of velocities and accelerations of followers with different types of motions are discussed in the following sections.

#### **(a) Follower motion with Uniform velocity:**

Fig.6.8 shows the displacement, velocity and acceleration patterns of a follower having uniform velocity type of motion. Since the follower moves with constant velocity, during rise and fall, the displacement varies linearly with  $\theta$ . Also, since the velocity changes from zero to a finite value, within no time, theoretically, the acceleration becomes infinite at the beginning and end of rise and fall.

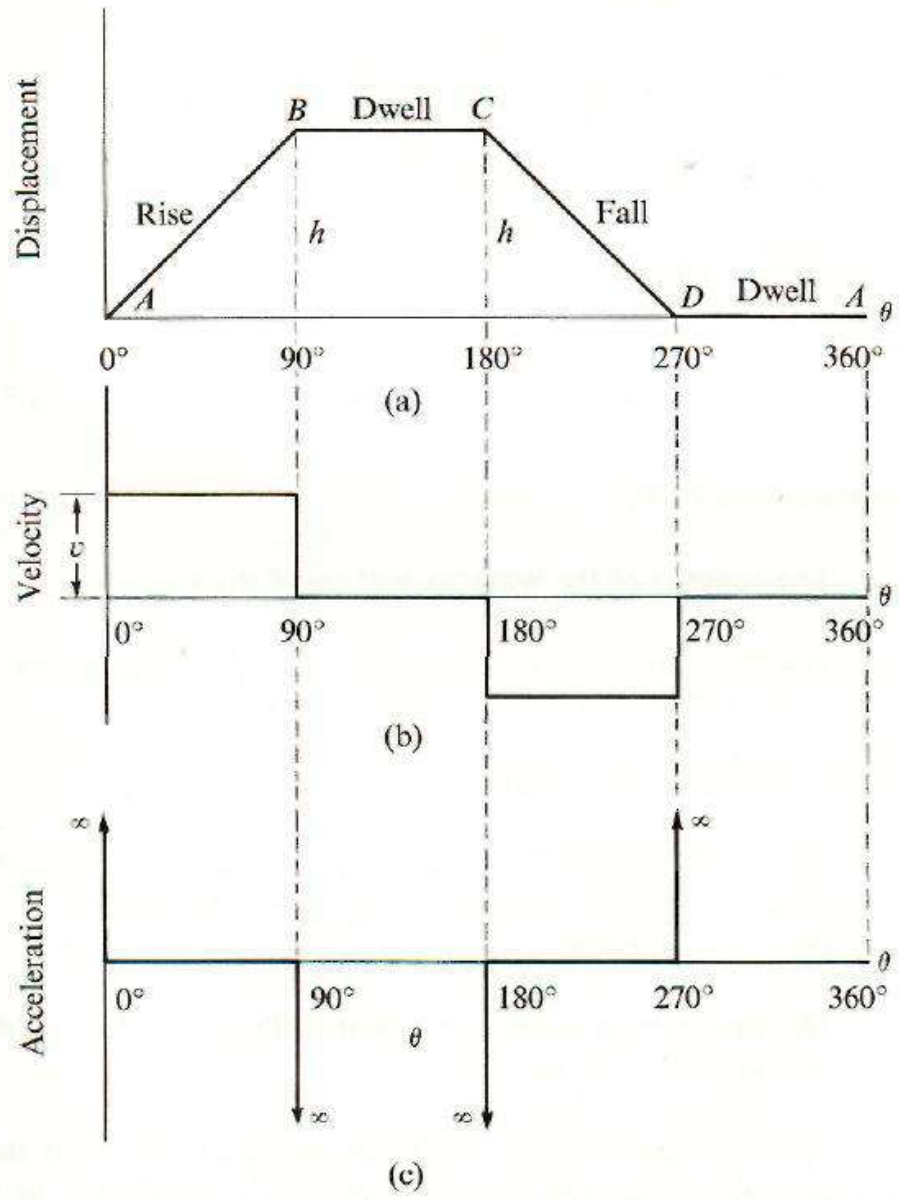
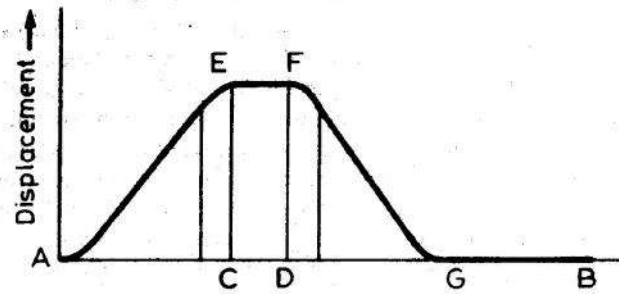

Fig.6.8

**(b) Follower motion with modified uniform velocity:**

It is observed in the displacement diagrams of the follower with uniform velocity that the acceleration of the follower becomes infinite at the beginning and ending of rise and return strokes. In order to prevent this, the displacement diagrams are slightly modified. In the modified form, the velocity of the follower changes uniformly during the beginning and end of each stroke. Accordingly, the displacement of the follower varies parabolically during these periods. With this modification, the acceleration becomes constant during these periods, instead of being infinite as in the uniform velocity type of motion. The displacement, velocity and acceleration patterns are shown in **fig.6.9**.



(a) Displacement diagram

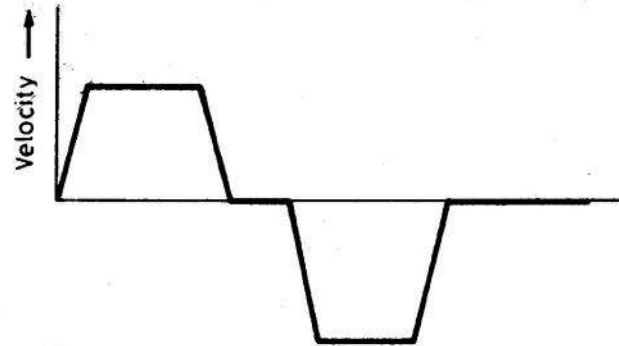

(b) Velocity diagram

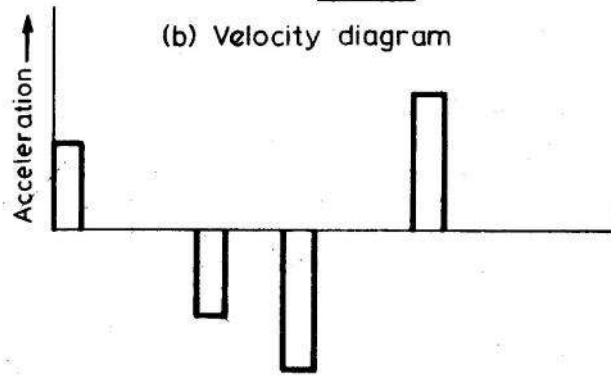
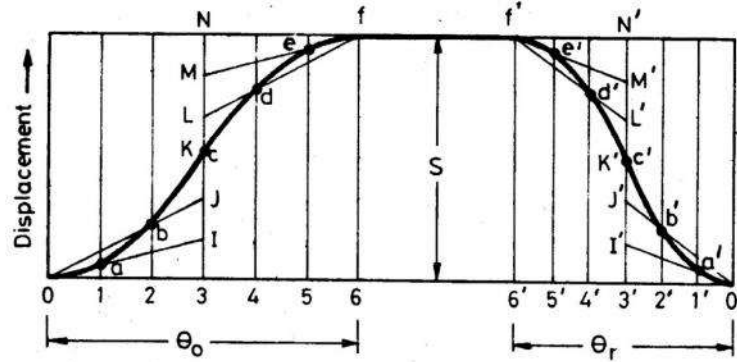

fig.6.9

**(c) Follower motion with uniform acceleration and retardation (UARM):**

Here, the displacement of the follower varies parabolically with respect to angular displacement of cam. Accordingly, the velocity of the follower varies uniformly with respect to angular displacement of cam. The acceleration/retardation of the follower becomes constant accordingly. The displacement, velocity and acceleration patterns are shown in **fig. 6.10**.



(a) Displacement diagram

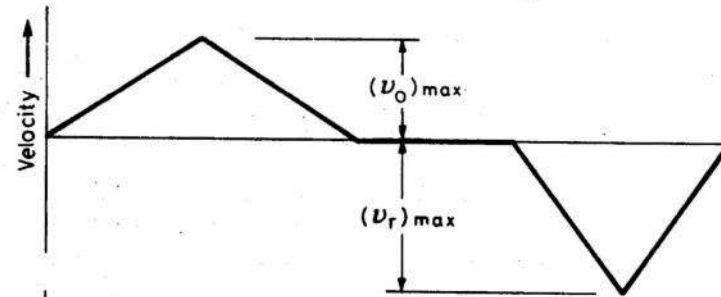

(b) Velocity diagram

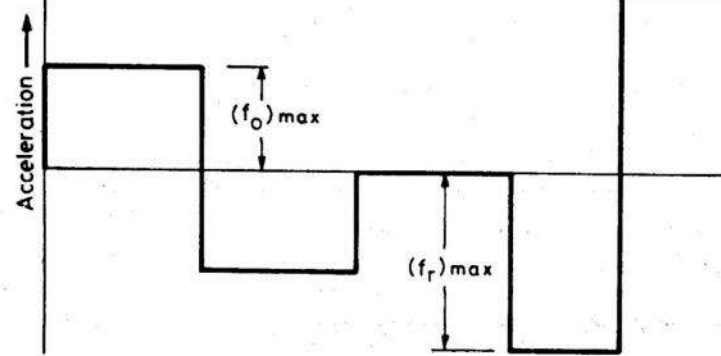

(c) Acceleration diagram

**Fig.6.10**

$s$  = Stroke of the follower

$\theta_o$  and  $\theta_r$  = Angular displacement of the cam during outstroke and return stroke.

$\omega$  = Angular velocity of cam.

$$\text{Time required for follower outstroke} = t_o = \frac{\theta_o}{\omega}$$

$$\text{Time required for follower return stroke} = t_r = \frac{\theta_r}{\omega}$$

$$\text{Average velocity of follower} = \frac{s}{t}$$

$$\text{Average velocity of follower during outstroke} = \frac{s/2}{t_o/2} = \frac{s}{t_o} = \frac{v_{o_{\min}} + v_{o_{\max}}}{2}$$

$$v_{o_{\min}} = 0$$

$$\therefore v_{o_{\max}} = \frac{2s}{t_o} = \frac{2\check{S}s}{\check{t}_o} = \text{Max. velocity during outstroke.}$$

$$\text{Average velocity of follower during return stroke} = \frac{s/2}{t_r/2} = \frac{s}{t_r} = \frac{v_{r_{\min}} + v_{r_{\max}}}{2}$$

$$v_{r_{\min}} = 0$$

$$\therefore v_{r_{\max}} = \frac{2s}{t_r} = \frac{2\check{S}s}{\check{t}_r} = \text{Max. velocity during return stroke.}$$

$$\text{Acceleration of the follower during outstroke} = a_o = \frac{v_{o_{\max}}}{t_o/2} = \frac{4\check{S}^2 s}{\check{t}_o^2}$$

$$\text{Similarly acceleration of the follower during return stroke} = a_r = \frac{4\check{S}^2 s}{\check{t}_r^2}$$

**(d) Simple Harmonic Motion:** In fig.6.11, the motion executed by point P<sup>1</sup>, which is the projection of point P on the vertical diameter is called simple harmonic motion. Here, P moves with uniform angular velocity  $\check{\omega}_p$  along a circle of radius r (r = s/2).

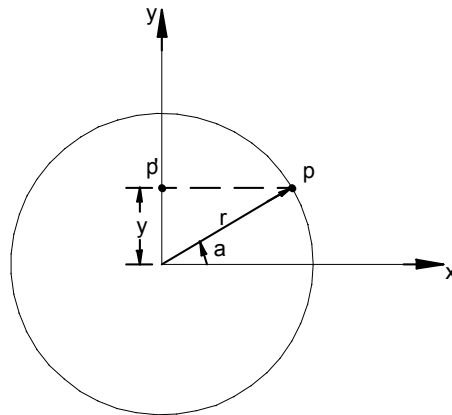

Fig.6.11

$$\text{Displacement} = y = r \sin \alpha = r \sin \check{S}_p t ; y_{\max} = r \quad [d1]$$

$$\text{Velocity} = \dot{y} = \check{S}_p r \cos \check{S}_p t ; \dot{y}_{\max} = r \check{S}_p \quad [d2]$$

$$\text{Acceleration} = \ddot{y} = -\check{S}_p^2 r \sin \check{S}_p t = -\check{S}_p^2 y ; \ddot{y}_{\max} = -r \check{S}_p^2 \quad [d3]$$

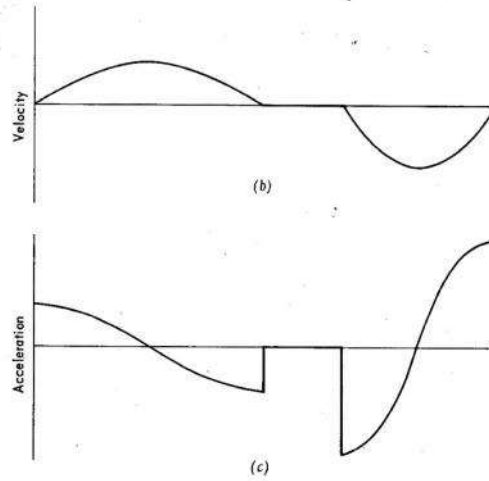
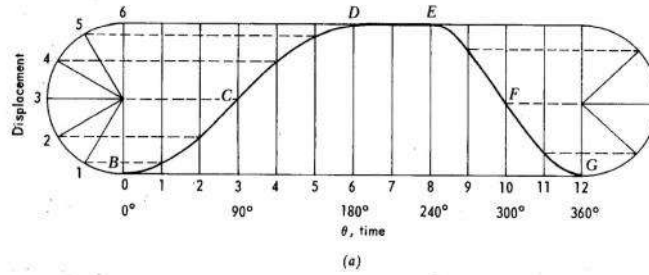

Fig.6.11

$s$  = Stroke or displacement of the follower.

$\theta_o$  = Angular displacement during outstroke.

$\theta_r$  = Angular displacement during return stroke

$\omega$  = Angular velocity of cam.

$$t_o = \text{Time taken for outstroke} = \frac{\theta_o}{\omega}$$

$$t_r = \text{Time taken for return stroke} = \frac{\theta_r}{\omega}$$

Max. velocity of follower during outstroke =  $v_{o_{\max}} = r_p$  (from d2)

$$v_{o_{\max}} = \frac{s}{2t_o} = \frac{f\omega s}{2\theta_o}$$

Similarly Max. velocity of follower during return stroke =  $v_{r_{\max}} = \frac{s}{2t_r} = \frac{f\omega s}{2\theta_r}$

Max. acceleration during outstroke =  $a_{o_{\max}} = r_p^2$  (from d3) =  $\frac{s}{2} \left( \frac{f}{t_o} \right)^2 = \frac{f^2 \omega^2 s}{2\theta_o^2}$

Similarly, Max. acceleration during return stroke =  $a_{r_{\max}} = \frac{s}{2} \left( \frac{f}{t_r} \right)^2 = \frac{f^2 \omega^2 s}{2\theta_r^2}$

**(e) Cycloidal motion:**

Cycloid is the path generated by a point on the circumference of a circle, as the circle rolls without slipping, on a straight/flat surface. The motion executed by the follower here, is similar to that of the projection of a point moving along a cycloidal curve on a vertical line as shown in figure 6.12.

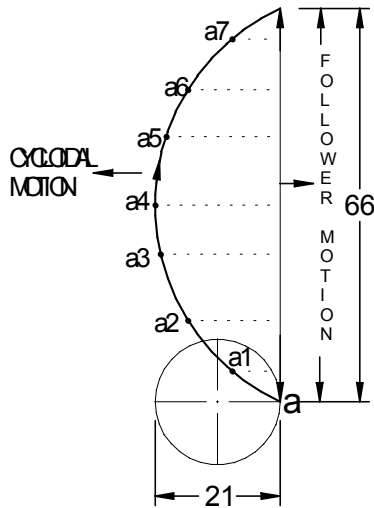

Fig.6.12

The construction of displacement diagram and the standard patterns of velocity and acceleration diagrams are shown in fig.6.13. Compared to all other follower motions, cycloidal motion results in smooth operation of the follower.

The expressions for maximum values of velocity and acceleration of the follower are shown below.

$s$  = Stroke or displacement of the follower.

$$d = \text{dia. of cycloid generating circle} = \frac{s}{f}$$

$\theta_o$  = Angular displacement during outstroke.

$\theta_r$  = Angular displacement during return stroke

$\omega$  = Angular velocity of cam.

$$t_o = \text{Time taken for outstroke} = \frac{\theta_o}{\omega}$$

$$t_r = \text{Time taken for return stroke} = \frac{\theta_r}{\omega}$$

$$v_{o_{\max}} = \text{Max. velocity of follower during outstroke} = \frac{2\omega s}{\theta_o}$$

$$v_{r_{\max}} = \text{Max. velocity of follower during return stroke} = \frac{2\omega s}{\theta_r}$$

$$a_{o_{\max}} = \text{Max. acceleration during outstroke} = \frac{2f\check{S}^2s}{\omega_o^2}$$

$$a_{r_{\max}} = \text{Max. acceleration during return stroke} = \frac{2f\check{S}^2s}{\omega_r^2}$$

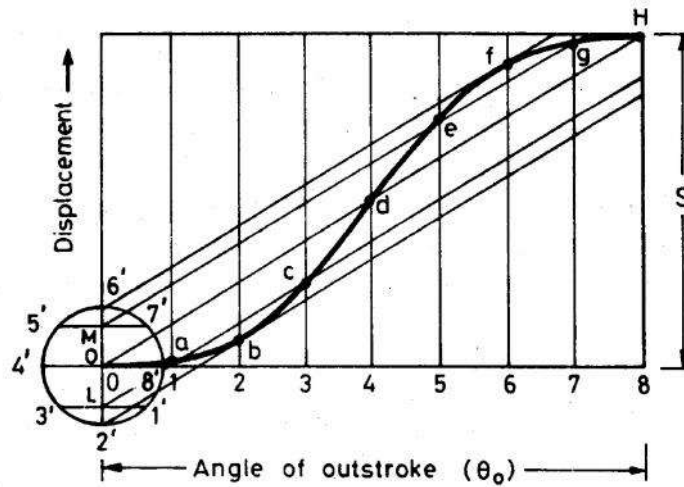

(a) Displacement diagram

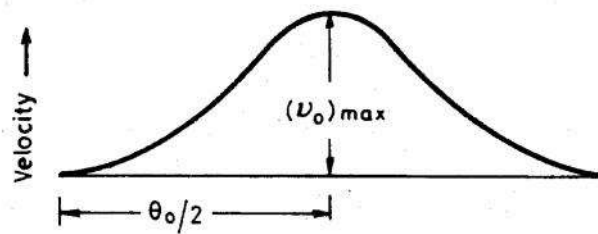

(b) Velocity diagram

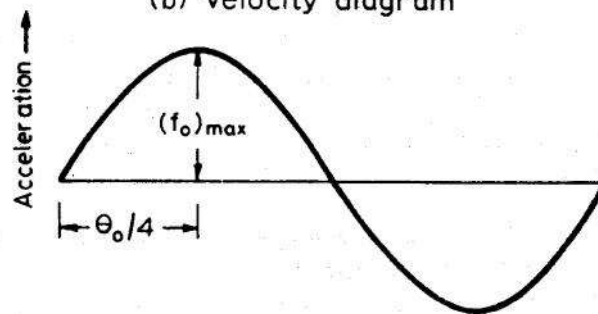

(c) Acceleration diagram

Fig. 6.13

**Solved problems**

**(1) Draw the cam profile for following conditions:**

Follower type = Knife edged, in-line; lift = 50mm; base circle radius = 50mm; out stroke with SHM, for  $60^\circ$  cam rotation; dwell for  $45^\circ$  cam rotation; return stroke with SHM, for  $90^\circ$  cam rotation; dwell for the remaining period. Determine max. velocity and acceleration during out stroke and return stroke if the cam rotates at 1000 rpm in clockwise direction.

**Displacement diagram:**

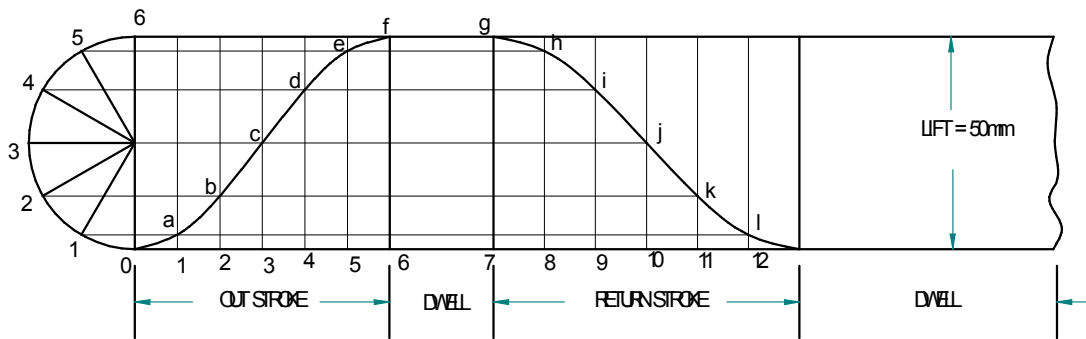

**Cam profile:** Construct base circle. Mark points 1,2,3.....in direction opposite to the direction of cam rotation. Transfer points a,b,c.....l from displacement diagram to the cam profile and join them by a smooth free hand curve. This forms the required cam profile.

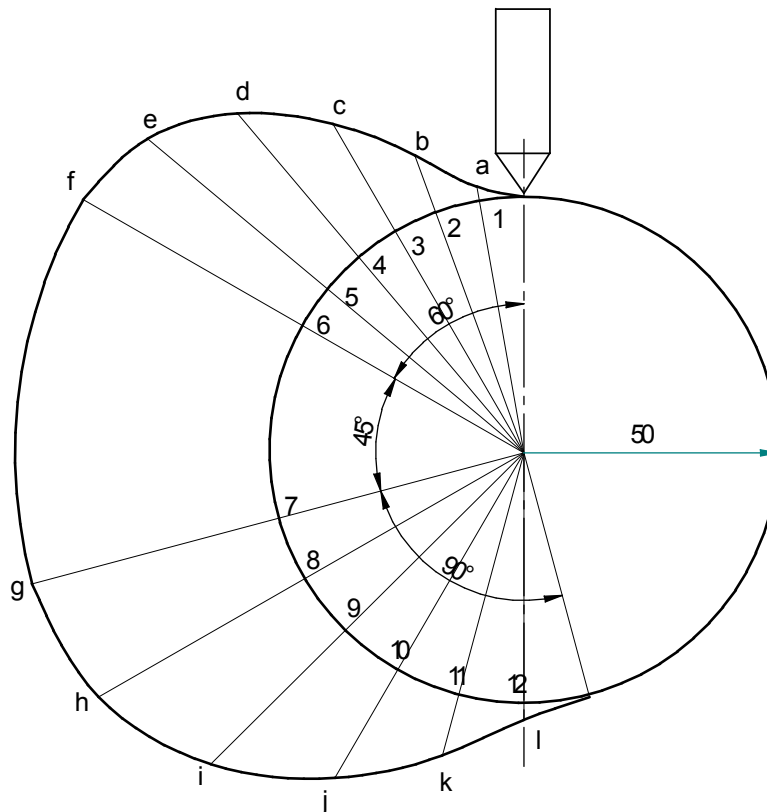

**Calculations:**

$$\text{Angular velocity of cam} = \check{S} = \frac{2fN}{60} = \frac{2 \times f \times 1000}{60} = \mathbf{104.76 \text{ rad/sec}}$$

$$\begin{aligned} \text{Max. velocity of follower during outstroke} &= v_{o_{\max}} = \frac{f\check{S}s}{2r_o} = \\ &= \frac{f \times 104.76 \times 50}{2 \times f/3} = 7857 \text{ mm/sec} = \mathbf{7.857 \text{ m/sec}} \end{aligned}$$

$$\begin{aligned} \text{Similarly Max. velocity of follower during return stroke} &= v_{r_{\max}} = \frac{f\check{S}s}{2r_r} = \\ &= \frac{f \times 104.76 \times 50}{2 \times f/2} = 5238 \text{ mm/sec} = \mathbf{5.238 \text{ m/sec}} \end{aligned}$$

$$\begin{aligned} \text{Max. acceleration during outstroke} &= a_{o_{\max}} = r_p^2 \text{ (from d3)} = \frac{f^2\check{S}^2s}{2r_o^2} = \\ &= \frac{f^2 \times (104.76)^2 \times 50}{2 \times (f/3)^2} = 2469297.96 \text{ mm/sec}^2 = \mathbf{2469.3 \text{ m/sec}^2} \end{aligned}$$

$$\begin{aligned} \text{Similarly, Max. acceleration during return stroke} &= a_{r_{\max}} = \frac{f^2\check{S}^2s}{2r_r^2} = \\ &= \frac{f^2 \times (104.76)^2 \times 50}{2 \times (f/2)^2} = 1097465.76 \text{ mm/sec}^2 = \mathbf{1097.5 \text{ m/sec}^2} \end{aligned}$$

(2) Draw the cam profile for the same operating conditions of problem (1), with the follower off set by 10 mm to the left of cam center.

**Displacement diagram:** Same as previous case.

**Cam profile:** Construction is same as previous case, except that the lines drawn from 1,2,3.... are tangential to the offset circle of 10mm dia. as shown in the fig.

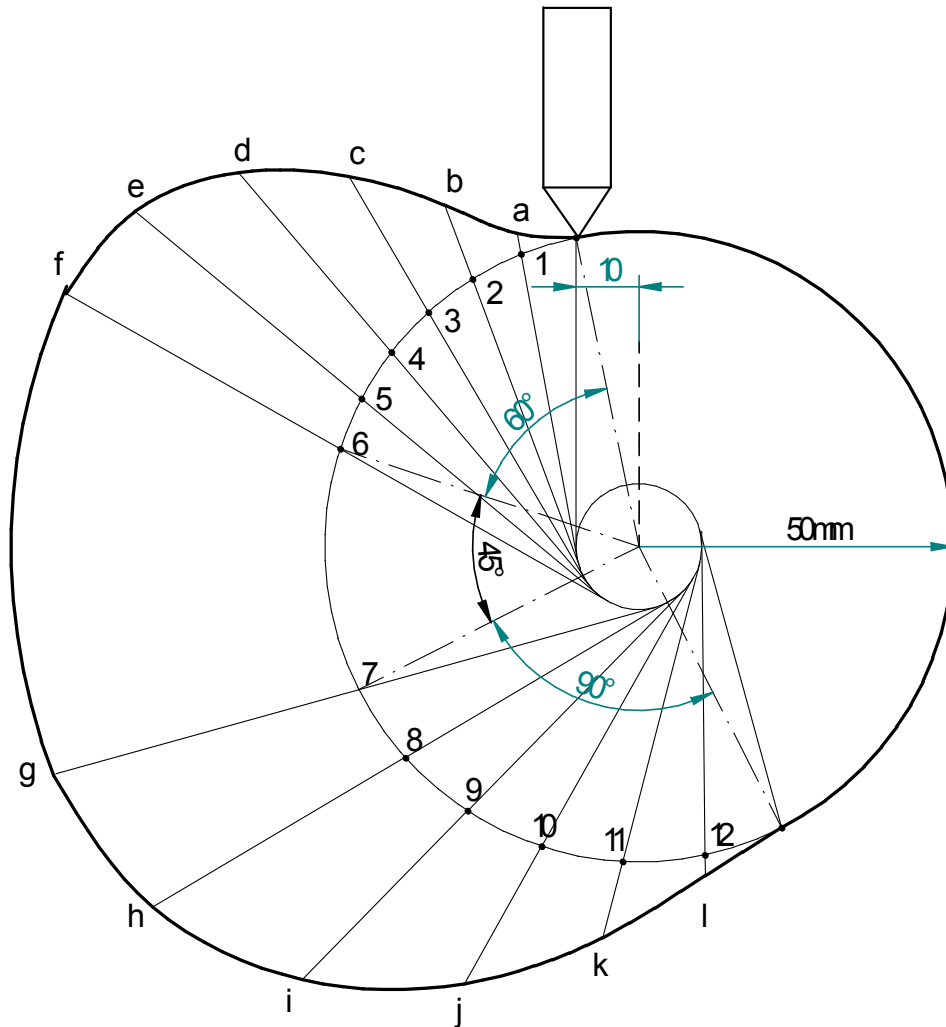

**(3) Draw the cam profile for following conditions:**

Follower type = roller follower, in-line; lift = 25mm; base circle radius = 20mm; roller radius = 5mm; out stroke with UARM, for  $120^\circ$  cam rotation; dwell for  $60^\circ$  cam rotation; return stroke with UARM, for  $90^\circ$  cam rotation; dwell for the remaining period. Determine max. velocity and acceleration during out stroke and return stroke if the cam rotates at 1200 rpm in clockwise direction.

**Displacement diagram:**

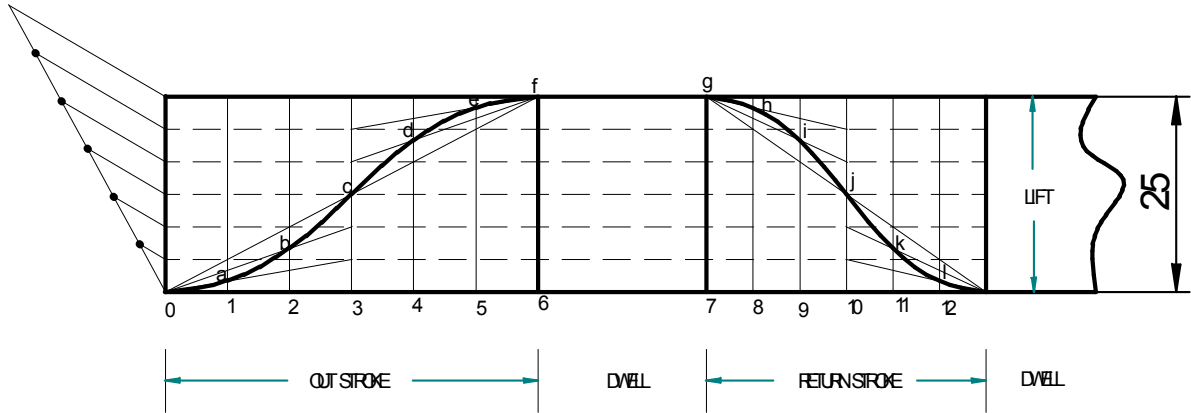

**Cam profile:** Construct base circle and prime circle (25mm radius). Mark points 1,2,3.....in direction opposite to the direction of cam rotation, on prime circle. Transfer points a,b,c.....l from displacement diagram. At each of these points a,b,c... draw circles of 5mm radius, representing rollers. Starting from the first point of contact between roller and base circle, draw a smooth free hand curve, tangential to all successive roller positions. This forms the required cam profile.

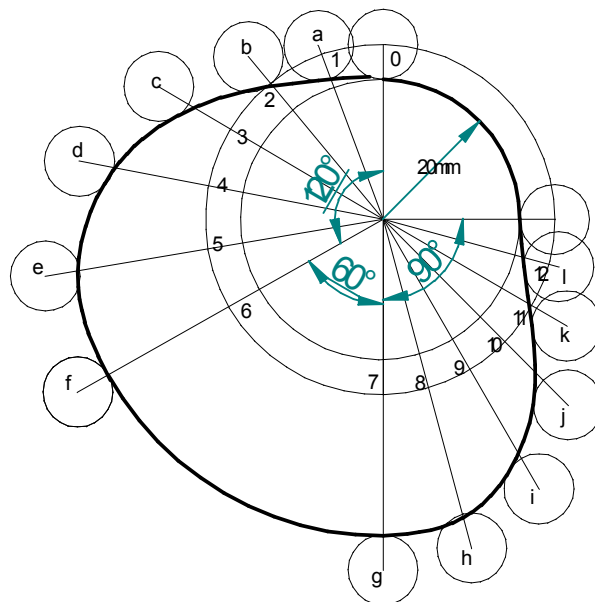

**Calculations:**

$$\text{Angular velocity of the cam} = \check{S} = \frac{2fN}{60} = \frac{2 \times f \times 1200}{60} = \mathbf{125.71 \text{ rad/sec}}$$

$$\begin{aligned} \text{Max. velocity during outstroke} &= v_{o_{\max}} = \frac{2s}{t_o} = \frac{2\check{S}s}{\text{" } o} = \\ &= \frac{2 \times 125.71 \times 25}{2 \times f / 3} = 2999.9 \text{ mm/sec} = \mathbf{2.999 \text{ m/sec}} \end{aligned}$$

$$\begin{aligned} \text{Max. velocity during return stroke} &= v_{r_{\max}} = \frac{2s}{t_r} = \frac{2\check{S}s}{\text{" } r} = \frac{2 \times 125.71 \times 25}{f/2} = \\ &= 3999.86 \text{ mm/sec} = \mathbf{3.999 \text{ m/sec}} \end{aligned}$$

$$\begin{aligned} \text{Acceleration of the follower during outstroke} &= a_o = \frac{v_{o_{\max}}}{t_o/2} = \frac{4\check{S}^2 s}{\text{" } o^2} = \\ &= \frac{4 \times (125.71)^2 \times 25}{(2 \times f / 3)^2} = 359975 \text{ mm/sec}^2 = \mathbf{359.975 \text{ m/sec}^2} \end{aligned}$$

$$\begin{aligned} \text{Similarly acceleration of the follower during return stroke} &= a_r = \frac{4\check{S}^2 s}{\text{" } r^2} = \\ &= \frac{4 \times (125.71)^2 \times 25}{(f/2)^2} = 639956 \text{ mm/sec}^2 = \mathbf{639.956 \text{ m/sec}^2} \end{aligned}$$

(4) Draw the cam profile for conditions same as in (3), with follower off set to right of cam center by 5mm and cam rotating counter clockwise.

**Displacement diagram:** Same as previous case.

**Cam profile:** Construction is same as previous case, except that the lines drawn from 1,2,3... are tangential to the offset circle of 10mm dia. as shown in the fig.

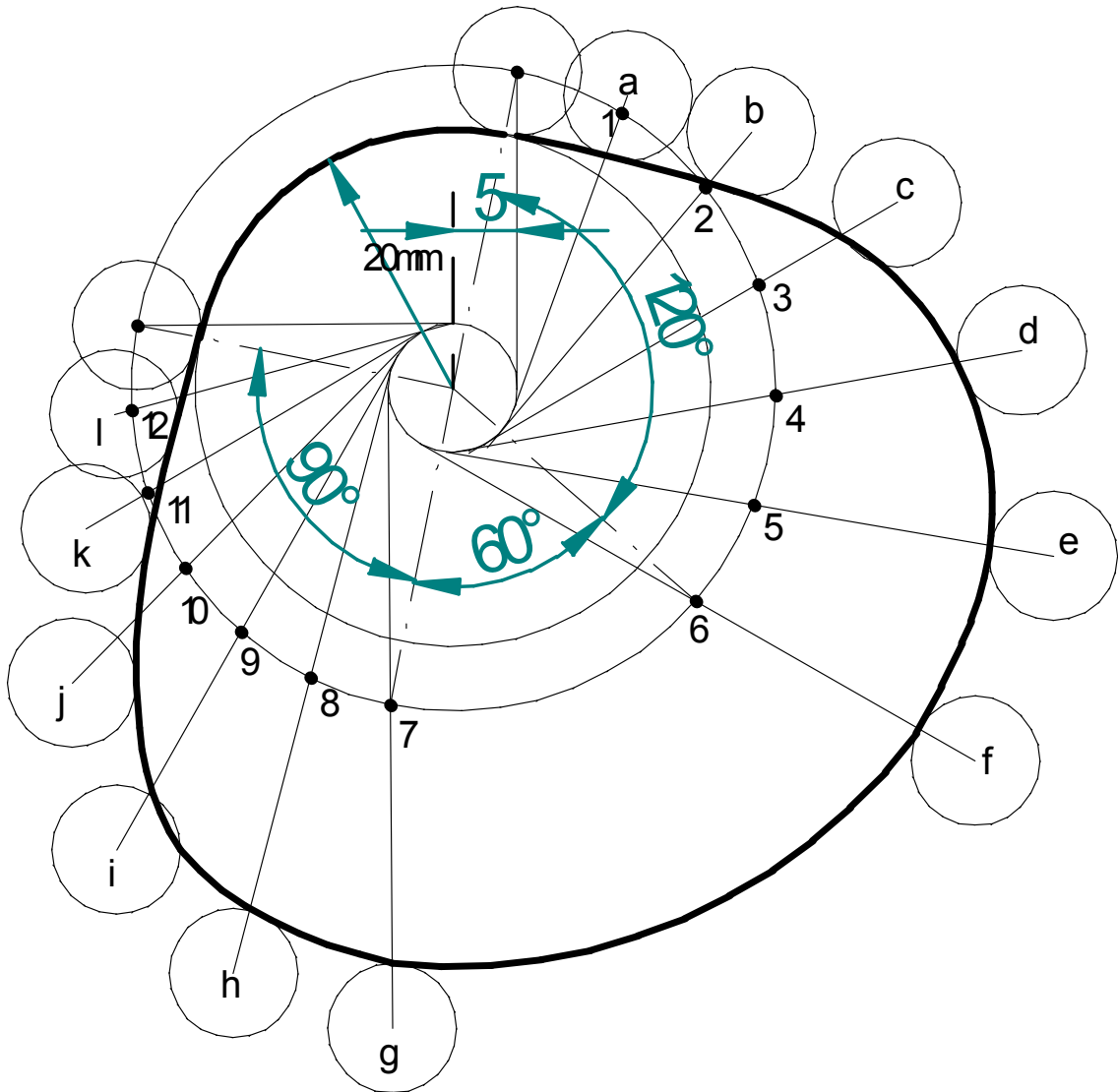

**(5) Draw the cam profile for following conditions:**

Follower type = roller follower, off set to the right of cam axis by 18mm; lift = 35mm; base circle radius = 50mm; roller radius = 14mm; out stroke with SHM in 0.05sec; dwell for 0.0125sec; return stroke with UARM, during 0.125sec; dwell for the remaining period. During return stroke, acceleration is 3/5 times retardation. Determine max. velocity and acceleration during out stroke and return stroke if the cam rotates at 240 rpm.

**Calculations:**

Cam speed = 240rpm. Therefore, time for one rotation =  $\frac{60}{240} = 0.25 \text{ sec}$

Angle of out stroke =  $\theta_o = \frac{0.05}{0.25} \times 360 = 72^\circ$

Angle of first dwell =  $\theta_{w1} = \frac{0.0125}{0.25} \times 360 = 18^\circ$

Angle of return stroke =  $\theta_r = \frac{0.125}{0.25} \times 360 = 180^\circ$

Angle of second dwell =  $\theta_{w2} = 90^\circ$

Since acceleration is 3/5 times retardation during return stroke,

$a = \frac{3}{5}r$  (from acceleration diagram)  $\therefore \frac{a}{r} = \frac{3}{5}$

But  $a = \frac{v_{\max}}{t_a}$ ;  $r = \frac{v_{\max}}{t_r}$   $\therefore \frac{a}{r} = \frac{t_r}{t_a} = \frac{3}{5}$

Displacement diagram is constructed by selecting  $t_a$  and  $t_r$  accordingly.

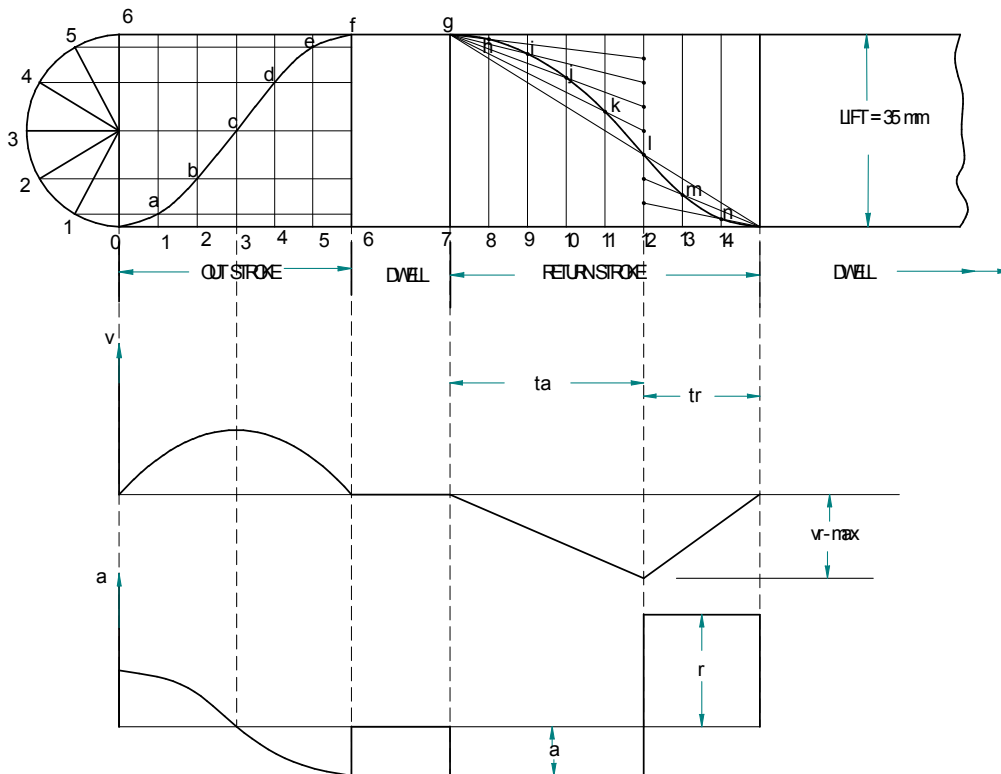

$$\text{Angular velocity of cam} = \check{S} = \frac{2fN}{60} = \frac{2 \times f \times 240}{60} = \mathbf{25.14 \text{ rad/sec}}$$

$$\begin{aligned} \text{Max. velocity of follower during outstroke} &= v_{o_{\max}} = \frac{f\check{S}s}{2n_o} = \\ &= \frac{f \times 25.14 \times 35}{2 \times (2 \times f/5)} = 1099.87 \text{ mm/sec} = \mathbf{1.1 \text{ m/sec}} \end{aligned}$$

$$\begin{aligned} \text{Similarly Max. velocity during return stroke} &= v_{r_{\max}} = \frac{2\check{S}s}{n_r} = \frac{2 \times 25.14 \times 35}{f} = \\ &= 559.9 \text{ mm/sec} = \mathbf{0.56 \text{ m/sec}} \end{aligned}$$

$$\begin{aligned} \text{Max. acceleration during outstroke} &= a_{o_{\max}} = r_p^2 \text{ (from d3)} = \frac{f^2 \check{S}^2 s}{2n_o^2} = \\ &= \frac{f^2 \times (25.14)^2 \times 35}{2 \times (2 \times f/5)^2} = 69127.14 \text{ mm/sec}^2 = \mathbf{69.13 \text{ m/sec}^2} \end{aligned}$$

acceleration of the follower during return stroke =

$$a_r = \frac{v_{r_{\max}}}{t_a} = \frac{2\check{S}s/n_r}{5 \times f/8 \times \check{S}} = \frac{16 \times \check{S}^2 \times s}{5 \times f \times n_r} = \frac{16 \times (25.14)^2 \times 35}{5 \times f \times f} = 7166.37 \text{ mm/sec}^2 = \mathbf{7.17 \text{ m/sec}^2}$$

similarly retardation of the follower during return stroke =

$$r_r = \frac{v_{r_{\max}}}{t_r} = \frac{2\check{S}s/n_r}{3 \times f/8 \times \check{S}} = \frac{16 \times \check{S}^2 \times s}{3 \times f \times n_r} = \frac{16 \times (25.14)^2 \times 35}{3 \times f \times f} = 11943.9 \text{ mm/sec}^2 = \mathbf{11.94 \text{ m/sec}^2}$$

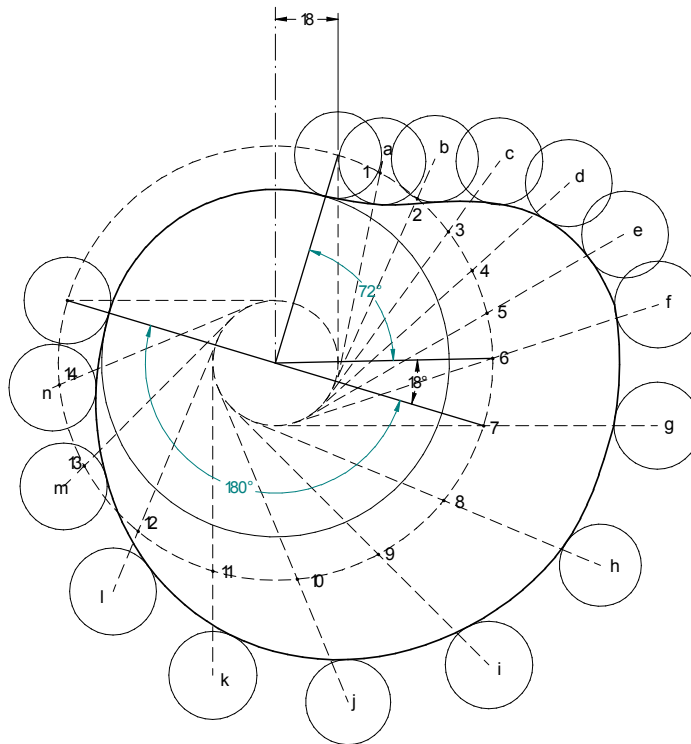

**(6) Draw the cam profile for following conditions:**

Follower type = knife edged follower, in line; lift = 30mm; base circle radius = 20mm; out stroke with uniform velocity in  $120^\circ$  of cam rotation; dwell for  $60^\circ$ ; return stroke with uniform velocity, during  $90^\circ$  of cam rotation; dwell for the remaining period.

**Displacement diagram:**

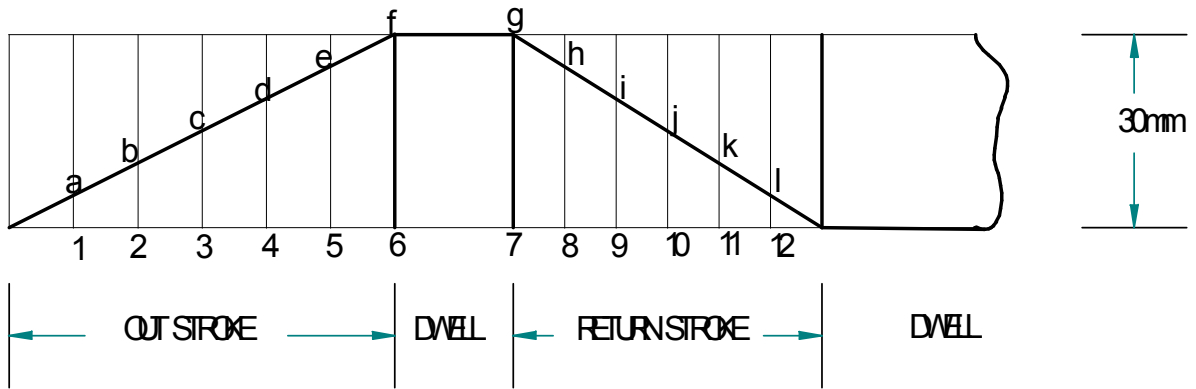

**Cam profile:**

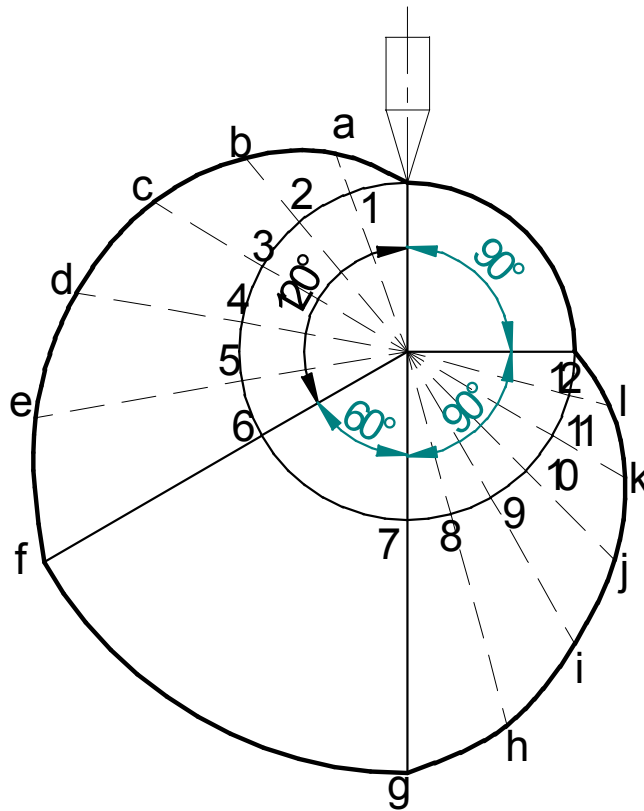

**(7) Draw the cam profile for following conditions:**

Follower type = oscillating follower with roller as shown in fig.; base circle radius = 20mm; roller radius = 7mm; follower to rise through 40° during 90° of cam rotation with cycloidal motion; dwell for 30°; return stroke with cycloidal motion during 120° of cam rotation; dwell for the remaining period. Also determine the max. velocity and acceleration during outstroke and return stroke, if the cam rotates at 600 rpm.

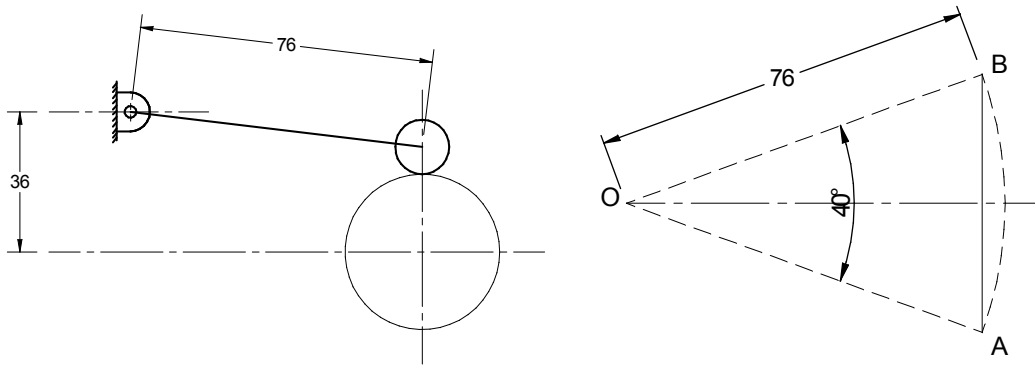

Lift of the follower =  $S = \text{length } AB \approx \text{arc } AB = OA \times \theta = 76 \times 40 \times \frac{f}{180} = 53 \text{ mm.}$

Radius of cycloid generating circle =  $\frac{53}{2 \times f} = 8.4 \text{ mm}$

**Displacement diagram;**

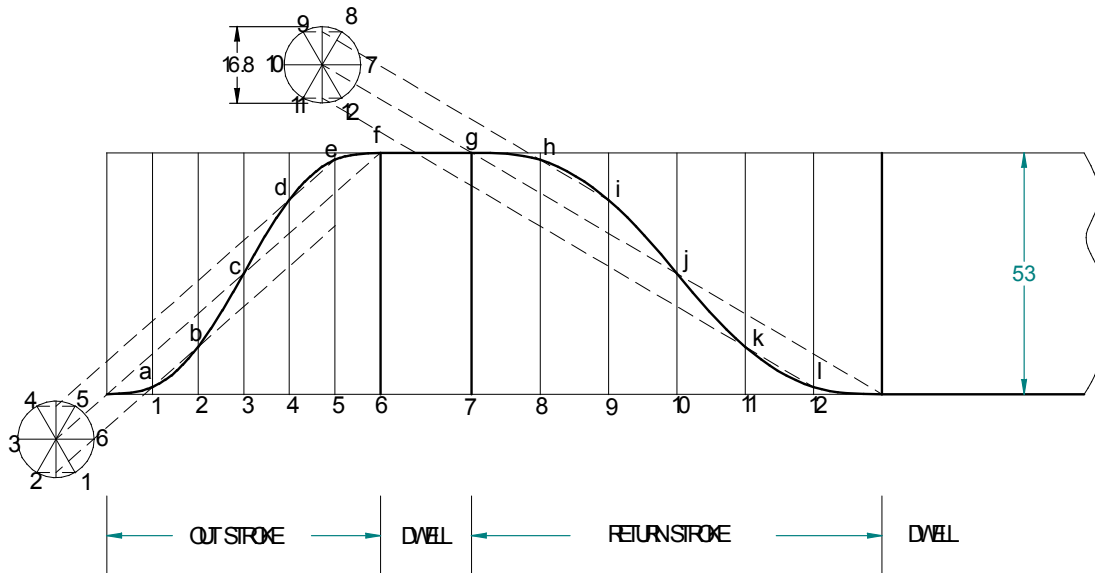

$$\text{Angular velocity of cam} = \dot{S} = \frac{2fN}{60} = \frac{2 \times f \times 600}{60} = 62.86 \text{ rad/sec}$$

$$v_{o_{\max}} = \text{Max. velocity of follower during outstroke} = \frac{2\dot{S}s}{f/2} = \frac{2 \times 62.86 \times 53}{f/2} = 4240.2 \text{ mm/sec}$$

$$v_{r_{\max}} = \text{Max. velocity of follower during return stroke} = \frac{2\dot{S}s}{2 \times f/3} = \frac{2 \times 62.86 \times 53}{2 \times f/3} = 3180 \text{ mm/sec}$$

$$a_{o_{\max}} = \text{Max. acceleration during outstroke} = \frac{2f\dot{S}^2 s}{(f/2)^2} = \frac{2 \times f \times (62.86)^2 \times 53}{(f/2)^2} = 533077 \text{ mm/sec}^2$$

$$= 533.1 \text{ m/sec}^2.$$

$$a_{r_{\max}} = \text{Max. acceleration during return stroke} = \frac{2f\dot{S}^2 s}{(2 \times f/3)^2} = \frac{2 \times f \times (62.86)^2 \times 53}{(2 \times f/3)^2} =$$

$$= 299855.8 \text{ mm/sec}^2 = 299.8 \text{ m/sec}^2.$$

**Cam profile:** Draw base circle and prime circle. Draw another circle of radius equal to the distance between cam center and follower pivot point. Take the line joining cam center and pivot point as reference and draw lines indicating successive angular displacements of cam. Divide these into same number of divisions as in the displacement diagram. Show points 1', 2', 3'... on the outer circle. With these points as centers and radius equal to length of follower arm, draw arcs, cutting the prime circle at 1,2,3.... Transfer points a,b,c... on to these arcs from displacement diagram. At each of these points a,b,c... draw circles of 7mm radius, representing rollers. Starting from the first point of contact between roller and base circle, draw a smooth free hand curve, tangential to all successive roller positions. This forms the required cam profile.

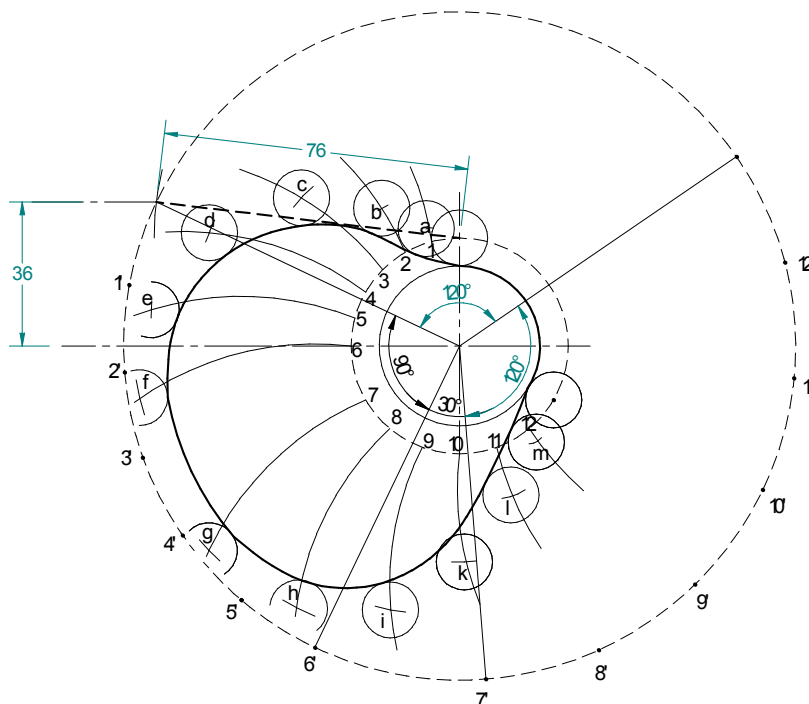

**(8) Draw the cam profile for following conditions:**

Follower type = knife edged follower, in line; follower rises by 24mm with SHM in 1/4 rotation, dwells for 1/8 rotation and then raises again by 24mm with UARM in 1/4 rotation and dwells for 1/16 rotation before returning with SHM. Base circle radius = 30mm.

$$\text{Angle of out stroke (1)} = \theta_{01} = \frac{1}{4} \times 360^\circ = 90^\circ$$

$$\text{Angle of dwell (1)} = \frac{1}{8} \times 360^\circ = 45^\circ$$

$$\text{Angle of out stroke (2)} = \theta_{02} = \frac{1}{4} \times 360^\circ = 90^\circ$$

$$\text{Angle of dwell (2)} = \frac{1}{16} \times 360^\circ = 22.5^\circ$$

$$\text{Angle of return stroke} = \theta_r = \left[ 1 - \left( \frac{1}{4} + \frac{1}{8} + \frac{1}{4} + \frac{1}{16} \right) \right] \times 360 = \frac{5}{16} \times 360^\circ = 112.5^\circ$$

**Displacement diagram:**

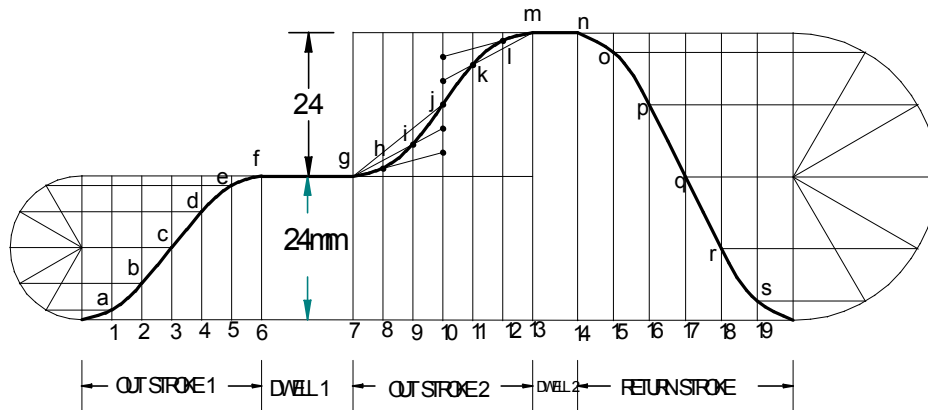

**Cam profile:**

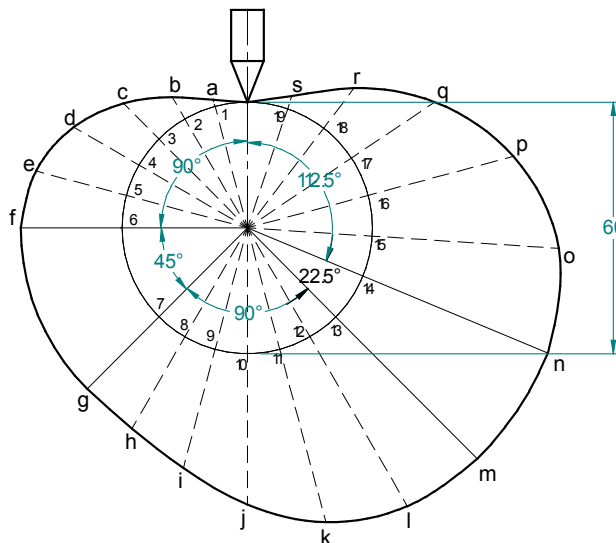

**(9) Draw the cam profile for following conditions:**

Follower type = flat faced follower, in line; follower rises by 20mm with SHM in  $120^\circ$  of cam rotation, dwells for  $30^\circ$  of cam rotation; returns with SHM in  $120^\circ$  of cam rotation and dwells during the remaining period. Base circle radius = 25mm.

**Displacement diagram:**

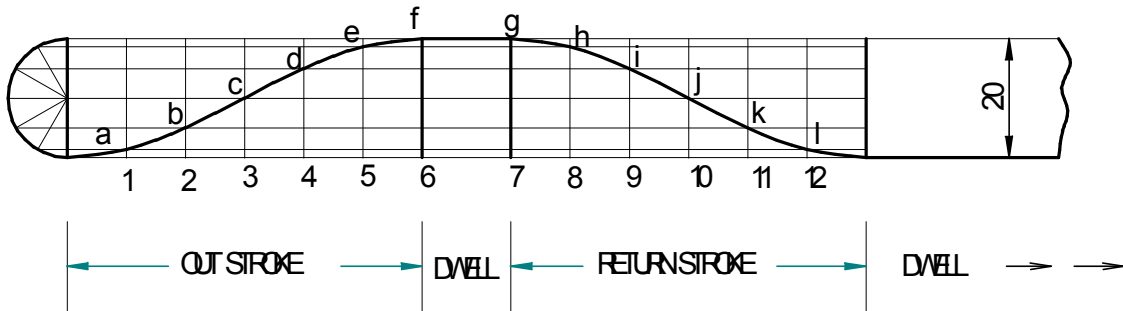

**Cam profile:** Construct base circle. Mark points 1,2,3....in direction opposite to the direction of cam rotation, on prime circle. Transfer points a,b,c....l from displacement diagram. At each of these points a,b,c... draw perpendicular lines to the radials, representing flat faced followers. Starting from the first point of contact between follower and base circle, draw a smooth free hand curve, tangential to all successive follower positions. This forms the required cam profile.

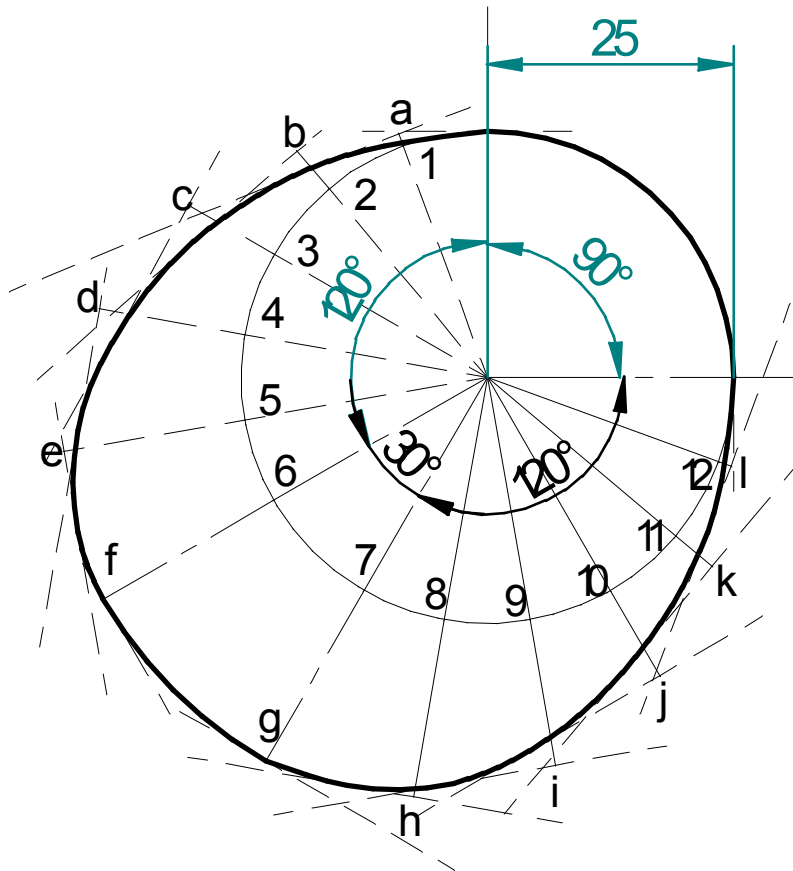

**(10) Draw the cam profile for following conditions:**

Follower type = roller follower, in line; roller dia. = 5mm; follower rises by 25mm with SHM in  $180^\circ$  of cam rotation, falls by half the distance instantaneously; returns with Uniform velocity in  $180^\circ$  of cam rotation. Base circle radius = 20m.

**Displacement diagram:**

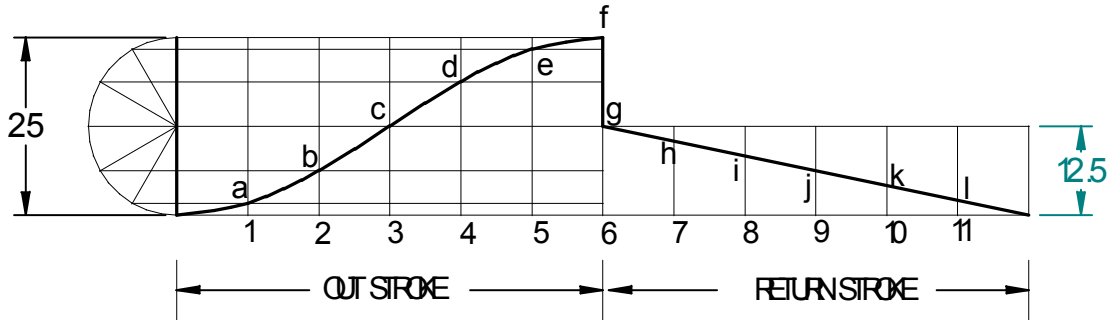

**Cam profile:**

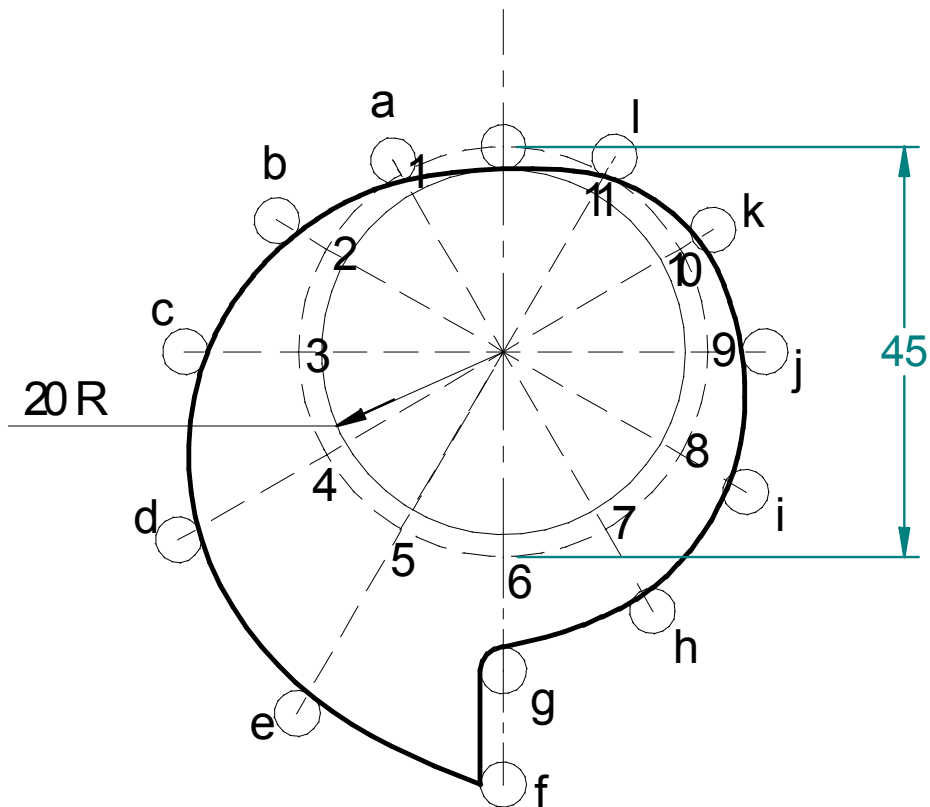

**(11) Draw the cam profile for following conditions:**

Follower type = roller follower, off-set to the right by 5mm; lift = 30mm; base circle radius = 25mm; roller radius = 5mm; out stroke with SHM, for  $120^\circ$  cam rotation; dwell for  $60^\circ$  cam rotation; return stroke during  $120^\circ$  cam rotation; first half of return stroke with Uniform velocity and second half with UARM; dwell for the remaining period.

**Displacement diagram:**

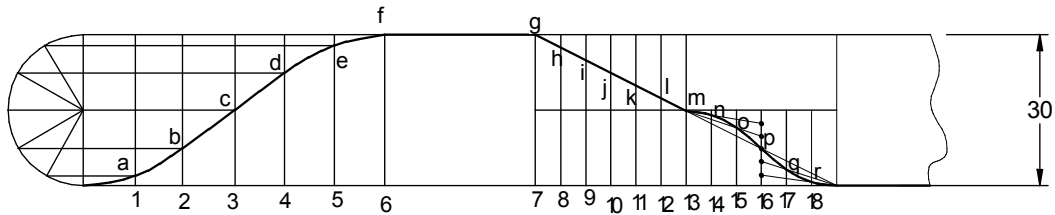

**Cam profile:**

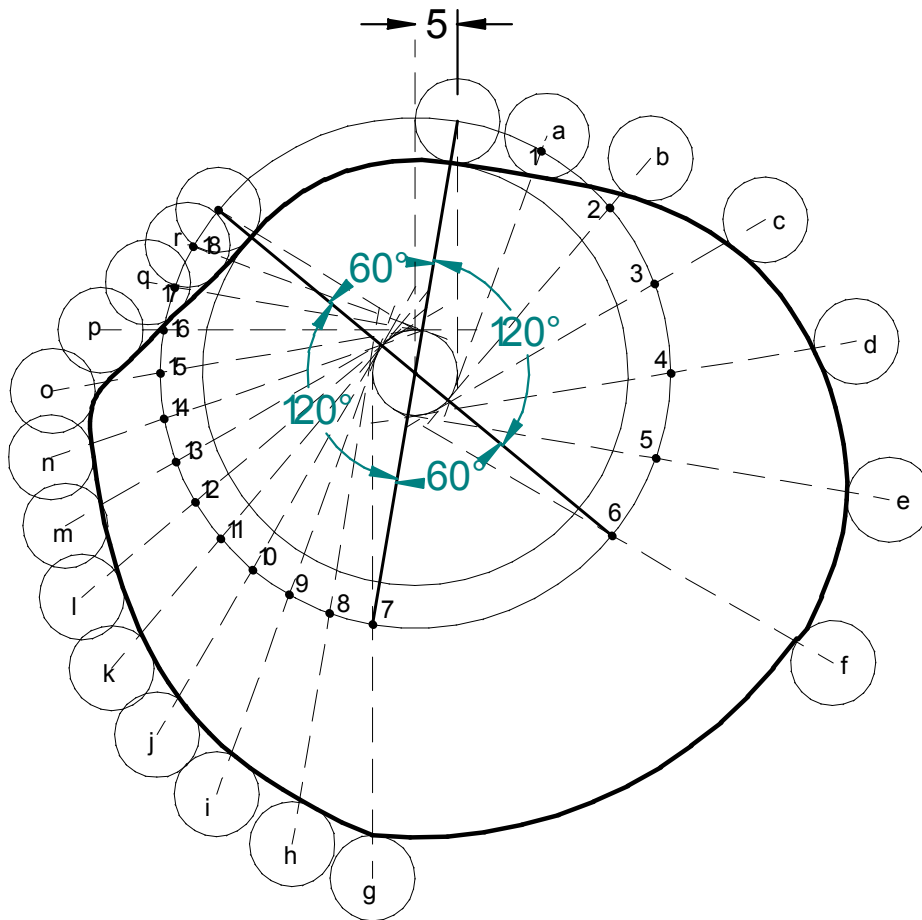

(12) A push rod of valve of an IC engine ascends with UARM, along a path inclined to the vertical at  $60^\circ$ . The same descends with SHM. The base circle diameter of the cam is 50mm and the push rod has a roller of 60mm diameter, fitted to its end. The axis of the roller and the cam fall on the same vertical line. The stroke of the follower is 20mm. The angle of action for the outstroke and the return stroke is  $60^\circ$  each, interposed by a dwell period of  $60^\circ$ . Draw the profile of the cam.

**Displacement diagram:**

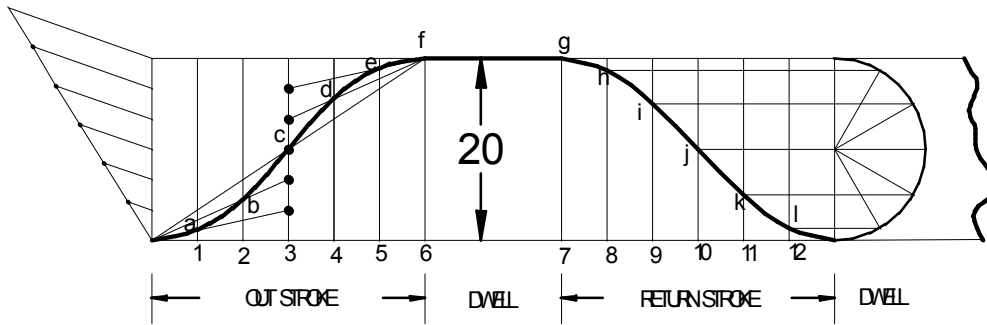

**Cam profile:**

